

User Manual

Digital Electrocardiograph

Model: QRS 12



About The User Manual

Please make sure to read all the content of this User Manual when installing and using the product for the first time.

To improve the performance and reliability of its parts, the product (including hardware and software) may be changed from time to time, during which, we will try to modify or add contents. Please forgive us as there may still be inconsistency with some descriptions. We look forward to your corrections in case of any errors and omissions in this manual.

All rights reserved © Infinium Medical, Inc.

Information contained in this document is proprietary to Infinium Medical, Inc. No part of this publication may be reproduced, stored in a retrieval system, or transmitted in any form, in whole or in part, by any means electronic, mechanical or other, including photocopying and recording, for any purpose without written permission of Infinium.



CAUTION: In US, Federal law restricts this device to sale by or on the order of a physician. Please read the user manual carefully prior to use.

Explanation of key words

WARNING

Indicates a potentially hazardous situation which, if not avoided, could result in death or serious injury.









CAUTION

Indicates a potentially hazardous situation which, if not avoided, may result in minor personal injury or equipment failure.

EXPLANATION

Indicates other important information besides warning or caution.

Explanation of symbols

Symbol	Explanation	Symbol	Explanation
~	Alternating Current Working		Type CF Applied Part
	Directing Current Working		Type CF Applied Part including Defibrillation-Proof
	Battery Charging	VGA	VGA Port
	DC Socket		LAN Port
	Equipotential Terminal		USB Port
	Caution! Please operate according to the User Manual.	SD	SD Card Slot

Conventions

Format	Explanation
"***"	Used to quote the texts in the software interface.
[****]	Used to quote the shortcut buttons or keys in the software interface.
TEXT	Used to quote the referenced chapters or sections in this manual.

Content	
Foreword	1
Chapter 1 Introduction	9
Equipment Overview	10
Front View	10
Back and Right View	11
Operating Buttons Area	12
Patient Cable	14
Waveform Display	14
Same Screen Display	15
Split-screen Display	16
Chapter 2 Preparing Recording	17
Location Selection	17
Load the Recording Paper	17
Power Supply Connection	18
Patient Cable Connection	19
Insert or Remove an SD card	20
Insert an SD card	20
Remove an SD Card	20
Power On/Off	21
Network Connection	21
Connect to a Wired Network	22
Connect to a Wireless Network (Optional)	22
Apply Electrodes	23
Electrodes Attachment	25
Lead Signals Formation Scheme	26
Chapter 3 Entering Patient Information	27
Enter Patient Information	27
Introduction of Input Method	28
User Manual for Electrocardiograph --I--	
Standard Character Keyboard	28
Digital Keyboard	29
Chapter 4 ECG Recording	31
Introduction of Sensitivities, Filters, and Print Speed	32
Record an ECG	33
Main Operation Process to Record ECG	34
Arrhythmia Detection	35
Introduction of Record Mode	36
Economic Recording Mode	37
Automatic Recording Mode	37
Manual Recording Mode	39
Cycle Recording Mode	39
Trigger Mode	39
Upload Mode	40
Advanced Mode	40
Rhythm Mode	40
Analysis Report Mode	41
Freeze Mode	44
Chapter 5 Setting System Parameters	45
ECG Setting	45
Print Setting	47

Display Setting	49
Patient Information	49
System Setting	49
Remote Report	52
Factory Maintain	53
Chapter 6 Data Management	55
Open an ECG File	56
Edit an ECG File	56
Delete ECG Files	56
Copy and Move ECG Files	57
Chapter 7 Maintenance	59
Main Unit	59
Patient Cable	59
Cleaning and Disinfection	59
Recording Paper	60
Battery	60
Silicon Rubber Shaft for Printing	62
Thermal Printing Head	62
Chapter 8 Troubleshooting	63
Lead Fault	63
Printer Failure	64
Keyboard Failure	64
Indication of Lead Off	65
AC Interference	65
EMG Interference	66
Baseline Wander	66
The ECG machine cannot be turned on	67
Paper Feeding Failure	67
Battery is quickly charged and discharged	68
Wrong Analysis Result	68
File Uploading Failed	69
Appendix A Package and Accessories	71
Packing List	71
Dimensions and Weight	72
Appendix B Technical Specification	73
Specifications	73
Main Unit	73
User Manual for Electrocardiograph --III--	
Recorder Specification	74
Other Specification	74
Environment Requirements	75
Appendix C Working Principle and Block Diagram	77
Power Supply Subsystem	77
Acquisition Module	78
Control System	79
Appendix D List of Interpretation Codes and Corresponding Description	81
Appendix E Measurement, Diagnosis, Analysis and Assessment of ECG Machine	87
Methods to determine the amplitude of P, QRS, ST and T wave	87
Processing method of isoelectric segment in QRS complex	89
Low incidence heart disease not included in testing and diagnosis database	90

ECG diagnosis categories and the number of ECG test of each category	90
The smallest waveform identified by the device and the stability of measurement when noise exists	91
Low incidence cardiac rhythm not included in the ECG rhythm test database	91
ECG rhythm diagnosis categories and ECG test number of each category	92
Sensitivity regularly test instructions	92
Distortion Test	93
Appendix F EMC- Guidance and manufacture's declaration	95
Guidance and manufacturer's declaration – electromagnetic emission	95
Guidance and manufacture's declaration-electromagnetic immunity for all EQUIPMENT and SYSTEMS.	
.....	96
.....	
Guidance and manufacture's declaration-electromagnetic immunity for EQUIPMENT and SYSTEMS those are not LIFE-SUPPORTING	97
Recommended separation distance between portable and mobile RF communications equipment and the EQUIPMENT or SYSTEM for EQUIPMENT or SYSTEM that are not LIFE-SUPPORTING	99

Foreword

 **CAUTION**

This ECG machine shall be used by qualified health professionals in the medical units, who need to analyze the ECG waveforms and give diagnostic results. In sequence to use this ECG machine correctly, safely and effectively, please read through the user manual carefully.

★ Safety Information

 **WARNING**

Avoid using and storing in the places with sulfur, salt, alkaline gas or with risk of gas leakage.

Avoid using in the places with anesthetic gases, flammable gases such as oxygen, hydrogen or other flammable chemicals, or it may cause explosion or fire.

Select a room with intact infrastructure (good power supply system and grounding facilities).

Be cautious when the patient is connected with more than one instrument, because the total leak current may be harmful to the patient. Devices in compliance with the standard of IEC60601-1 are allowed to be connected to this ECG machine, and the equipotential points of all the connected devices should be connected reliably. (The equipotential point and the protection ground of this ECG machine have been connected). Total leak current should be measured by the users to determine that it meets the requirement and can be used after connection.

All the analog and digital equipment that is connected to this ECG machine in the patient environment has to be in compliance with the standard IEC60601-1; All the analog and digital equipment that is connected to this ECG machine out of patient environment has to be in compliance with other national safety standards (IEC or ISO safety standards); the composition system should be in compliance with the standards of IEC 60601-1-1.

If a cardiac pacemaker is implanted in the patient, it might affect the accuracy of analysis result. In this case, the doctor is suggested to identify and analyze according to the waveforms.

When the equipment is used simultaneously with cardiac defibrillators, avoid contacting with patients or

hospital beds. All the electrodes connected and unconnected to patients as well as patients themselves do not have to be grounded. Do not use other electrical stimulators at the same time. If needed, it should be a professional technician to carry out the operation.

Chest and limb electrodes along with the device in the packing box could not meet the requirements of defibrillation polarization recovery time (however, they are essential accessories of ECG), should not be used immediately for reliable measurements and diagnostics after defibrillation. To ensure proper defibrillator protection, use only the recommended disposable electrodes (Name: Skintact; Type, RT-34), patient cable and electrode adapters by our company. To ensure the protection of defibrillator discharge, use the patient cable with defibrillation-proof by our company.

When the ECG machine is used together with a defibrillator or other electrical stimulators (like high-frequency surgical devices), we recommend using disposable chest electrodes. Otherwise the patient may get serious injury by using mental electrodes.

During defibrillation, the device can detect the discharge of defibrillator, and process automatically, and then quickly recover the waveform.

Keep the ECG machine electrodes away from the electrodes of high-frequency electrosurgical units. Ensure the resistance between the electrosurgical unit and patient body is as low as possible. If necessary, the disposable electrodes can be used because of its larger contact area on the human body, which can keep the high-frequency current density in an acceptable range.

When the relevant packaging material including depleted batteries and scrapping products are disposed, please follow the local laws; the user should properly follow requirements of local laws and recycling laws.

CAUTION

Avoid contacting with water or other liquids, and avoid using and storing in spaces with too large barometric pressure, humidity and temperature beyond the prescribed standards, poor ventilation, or with excessive dust.

The ECG machine should be placed on the flat horizontal table and avoid strong vibration and mechanical shock while moving.

The frequency of AC power supply and system voltage should comply with the requirements. More importantly, the current capacity should be sufficient.

The instrument should not be surrounded by high-voltage cables, ultrasound equipment, electrotherapy machines and other high-power equipment.

To more accurately record the ECG, the equipment shall be placed in a quiet and comfortable environment.

The circuit of applied parts works based on floating ground and meets the safety standards in IEC60601-1 CF Type. It can be used in acquiring the body surface ECG signals, but cannot be applied to the heart directly.

Turn off the ECG machine if an accident happens.

Please clean and disinfect reusable electrodes with medical alcohol before usage.

The conductive parts of electrodes and connectors (including neutral electrodes) on the ECG machine should not in touch with other conductive parts.

Do not press the buttons with sharp or hard articles or it may cause permanent damage to the buttons.

Do not make any modifications to this ECG machine.

Perform regular maintenance and inspection for this ECG machine and all its accessories (at least once every six months).

The maintenance and repair of this ECG machine should be performed by experienced technicians. When there is any functional abnormality, it should be clearly identified to prevent the ECG machine from running with fault.

The electrical schematic diagrams and parts listed are only provided to a qualified repair station or technicians recognized by the company.

★ General Operation Precautions

Before operation:

CAUTION

Make sure the ECG machine is in a complete and normal condition and whether the recording paper is sufficient.

Make sure the temperature and humidity of operating environment comply with the requirements.

Do not operate the ECG machine in an environment with X-ray equipment, ultrasound scanners, or other similar equipment. This equipment may interfere with the unit. If necessary, please power off the mentioned equipment or move the ECG machine to an environment without interference.

Make sure the patient cable are connected correctly and are kept away from the AC power cable; and connect it correctly in accordance with the lead and color labels, or the ECG analysis will be inaccurate.

Make sure the equipotential cable of this ECG machine is reliably and properly connected.

Make sure the power cable is properly connected with the ECG machine and is not twisted with other cables or wires.

Put the lead wires in good order before connecting them to the electrodes.

Make sure the electrodes are in good contact with skin. Please refer to **Apply Electrodes** for details.

Please install the ECG machine near an AC power outlet. Cut off the power supply immediately when there is an emergency.

If the patient is nervous, please explain to the patient that ECG examination is easy and no harm.

Please keep the patient silent and motionless.

Use wide hospital beds and keep the patient from touching the metal parts of the hospital bed, which may cause interference in ECG waveform recording. Keep the Examination room silent and comfortable.

⚠ WARNING

All circuits those contact with the patients directly should be examined closely.

When using the battery as the power supply, please check the voltage and condition of the battery first and make sure the battery fully charged. For new batteries, please discharge and charge it fully before using.

Use only 3-core power cable when using AC power, otherwise hazard of electric shock to the patient and operator cannot be completely eliminated. If the power cable is not working, only the built-in battery can safely power the ECG machine.

Make sure equipotential connection is complete and reliable, or else only use the built-in battery.

In operation:

⚠ WARNING

The physician should observe the patients closely without leaving during the operation. If necessary, turn off the ECG machine and remove the electrodes to ensure patient's safety.

Prevent the patients from contacting the other parts of the ECG machine or other conductors except for the electrodes.

After operation:

 **CAUTION**

Please return to the main interface before turning off the ECG machine.

Remove the electrodes gently and do not pull the lead wires emphatically.

Clear up the ECG machine and all the accessories for trouble-free operation of next use.

About LCD Touch Screen

 **CAUTION**

Do not place any heavy objects onto the LCD screen or strike it, otherwise it could cause damage to LCD screen.

When not using it, please put it away or have a cover on it. Keep it away from water.

Do not use LCD screen with excessive force.

If the cursor is not responding to the touch, re-calibrate your touch screen.

No water or soft sticky material is allowed on the touch screen, otherwise it would cause touch error.

About lithium battery

 **WARNING**

Only the authorized installation or service engineer can open the battery cover and replace the battery; do use the same type of rechargeable lithium battery provided by our company.

The positive and negative terminals of the batteries cannot be reversed, or it could cause an explosion.

Do not connect the two polarities of the battery with metal wires. Otherwise, there will be the hazard of fire.

Do not use the battery near a heat source or in an environment with temperature up to 60 °C. Do not heat the battery or throw it into the fire.

Keep the battery away from water; do not drop the battery into the water.

Only the authorized installation or service engineer can open the battery cover and replace the battery; do use the same type of rechargeable lithium battery provided by our company.

Do not press any metal into the battery; Do not hammer or beat the battery or use other ways to damage the battery, otherwise it will cause heat, smoke, deforming or burning, which is very dangerous.

When you find battery leakage or its emitting unpleasant odors, please get away from it immediately. If the fluid leaks onto the skin or clothes, wash with clean water at once. If the electrolyte enters the eyes, do not rub the eyes, wash with clean water immediately, and then go to see a doctor.

The users need to check the battery status regularly. When the battery reaches the end of its lifetime, when it smells, deforms, discolor, contorts, the users should stop using and dispose of it according to local regulations.

★ EMC Considerations

This ECG machine conforms to the IEC60601-1-2, a safety standard for medical electronic devices or systems. However, the electromagnetic environment exceeding the limit or level defined by the standard IEC60601-1-2 will introduce the unwanted interference to the ECG machine, disable its intended functions or it will compromise its intended performance. Thus, if there is any discrepancy with this ECG machine compared to its intended functions during operation, please do not use it any longer until the adverse affect is identified and eliminated. The appropriate preventing measures are given below by this manual for such cases:

Influence of radiated electromagnetic wave:

The use of a mobile phone may affect this ECG machine. Instruct all the people around to turn off their mobile phone or mini-radio devices when any medical electronic device is in use.

Influence of impact and conductive electromagnetic waves:

The high frequency noise produced by other devices can be introduced into this ECG machine through the alternating current socket. Please identify the noise source first, and if possible, stop the working of related devices. If they are not allowed to be stopped, measures such as application of noise abatement device should be taken to minimize the influence.

Influence of static electricity:

The static electricity in a dry environment (indoor) may affect this ECG machine, especially in winter. Please humidify the indoor air or pre-discharge the static electricity on the cable and the electrocardiogram recording personnel prior to using this ECG machine.

Influence of thunder and lightning:

A thunder and lightning strike nearby may cause voltage surge in this ECG machine. You can unplug the power supply and run the ECG machine using its internal battery in case of any danger.

Instrument Classification

Methods	Class
By Type of Protection Against Electric Shock	Class I, internal power supply
By Degree of Protection Against Electric Shock	Type CF applied part
By Degree of Liquid Proof	Ordinary equipment (enclosed device without liquid proof)
By Level of Protection Against Explosion	This equipment is unsuitable for use in an environment with air, oxygen or nitrous oxide mixed with flammable anesthetic gas.
By Mode of Operation	Continuous operation equipment

Maintenance Warranty

Our company guarantees the new instrument on the material and technological qualification for this product within 24 months and the accessories within 2 months since purchasing day, while consumables are not covered by the guarantee in principle. This guarantee is also inapplicable to the products undergoing any modification, disassembly, refitting or self-repairing without permission of our company, as well as the products damaged by accidents, fire disaster, thunder and lightning, flood and other disaster, intentional damage, improper installation and improper usage.

CAUTION

For all dated reference documents in this manual, its subsequent amendments (excluding corrections) or revisions do not apply to this manual; for undated reference documents, the latest version applies in this manual.

Due to product improvement, the content of this User Manual may differ from the product you purchased, which will not affect the usage, please operate according to the actual functions of the product.

This manual is subject to change without prior notice. We apologize for any inconvenience caused.

-- *Blank Page* --

Chapter 1 Introduction

Composition

The ECG machine is mainly composed of the main unit, patient cables, limb electrodes, chest electrodes and power adaptor.

Scope of Application

This ECG machine is used to extract the electrocardio complex from the human body to conduct form and rhythm analysis for clinical diagnosis and research.

Intended Use

The diagnostic applications include: check the cardiac abnormalities of the general population; detect the chest pain in patients with acute myocardial ischemia and myocardial infarction, and evaluate the patients with arrhythmias;

Suitable for: adults (older than 12 years old), pediatrics (age between 29 days to 12 years old), and neonates (infants born less than 28 days after 37 weeks to 44 weeks of pregnancy);

Used in: hospitals, clinics;

The automatic analysis program of this ECG machine focuses on the high sensitivity of detecting high-risk patients with cardiac abnormalities.

1 Equipment Overview

Front View

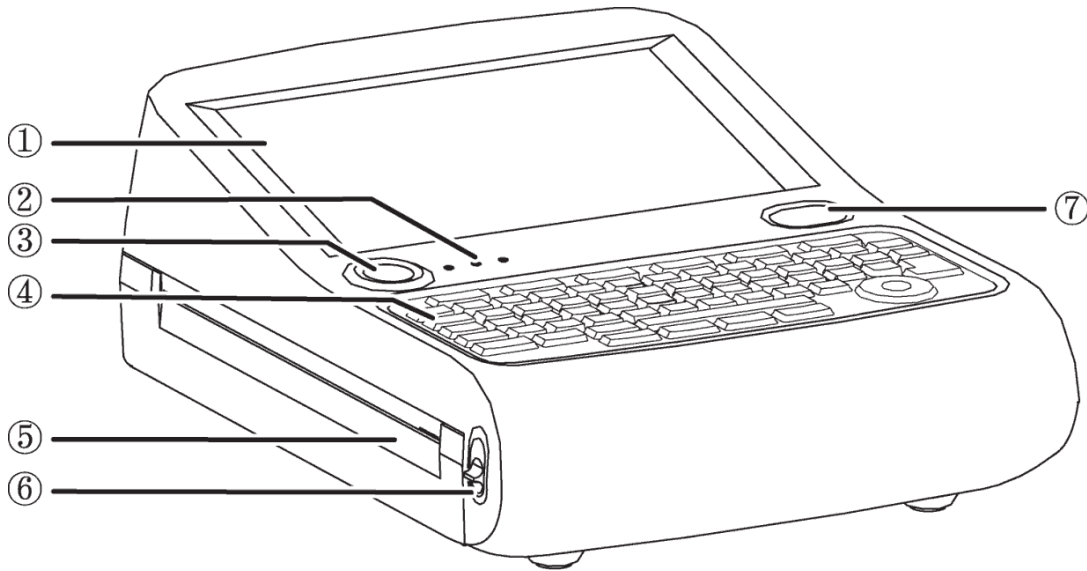





Figure 1-1 Front View

Number	Name	Description
1	LCD Touch Screen	Display the electrocardiogram, patient information and the equipment status.
2		Indicate the power status of the ECG machine. From left to right: AC power indicator, battery indicator and charging indicator.
3		Press to power on/off the ECG machine. If the ECG machine crashes, press and hold for 3 seconds to restart the ECG machine.
4	Operating Buttons	For controlling the operations to this ECG machine and inputting information. Refer to <i>Operating buttons area</i> to get more detailed information.
5	Paper Tray	Load the recording paper.
6	Switch Button	Push to open the Paper tray.

7		Start or stop printing the ECG waveforms and report.
---	---	--

Back and Right View

We have two types of patient cable sockets optional. Refer to Figure 1-2.

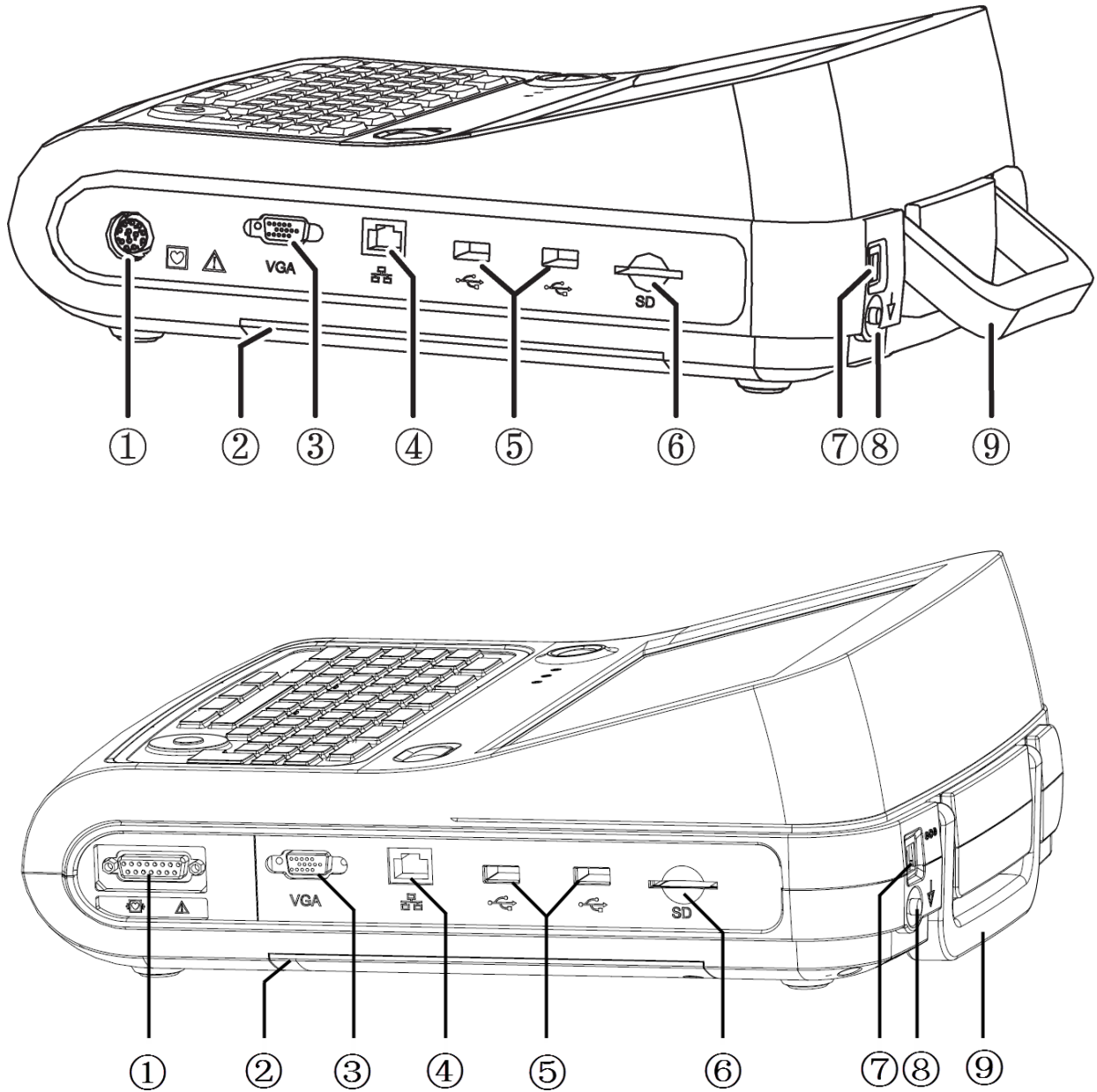

Figure 1-2 Side and Back View

Number	Name	Description
1	Patient Cable Socket	Connect to the patient cable.
2	Battery compartment	Load the rechargeable lithium battery.
3	VGA Port	/

4	LAN Port	Connect to LAN cable.
---	----------	-----------------------

Number	Name	Description
5	USB Port	Insert a USB device or connect to a bar scanner.
6	SD Card Slot	Insert an SD card.
7	Power Supply Socket	Connect to the AC power adaptor.
8	Equipotential Terminal	Connect to the equipotential cable.
9	Handle	Help the user carry the ECG machine easily.

Operating Buttons Area

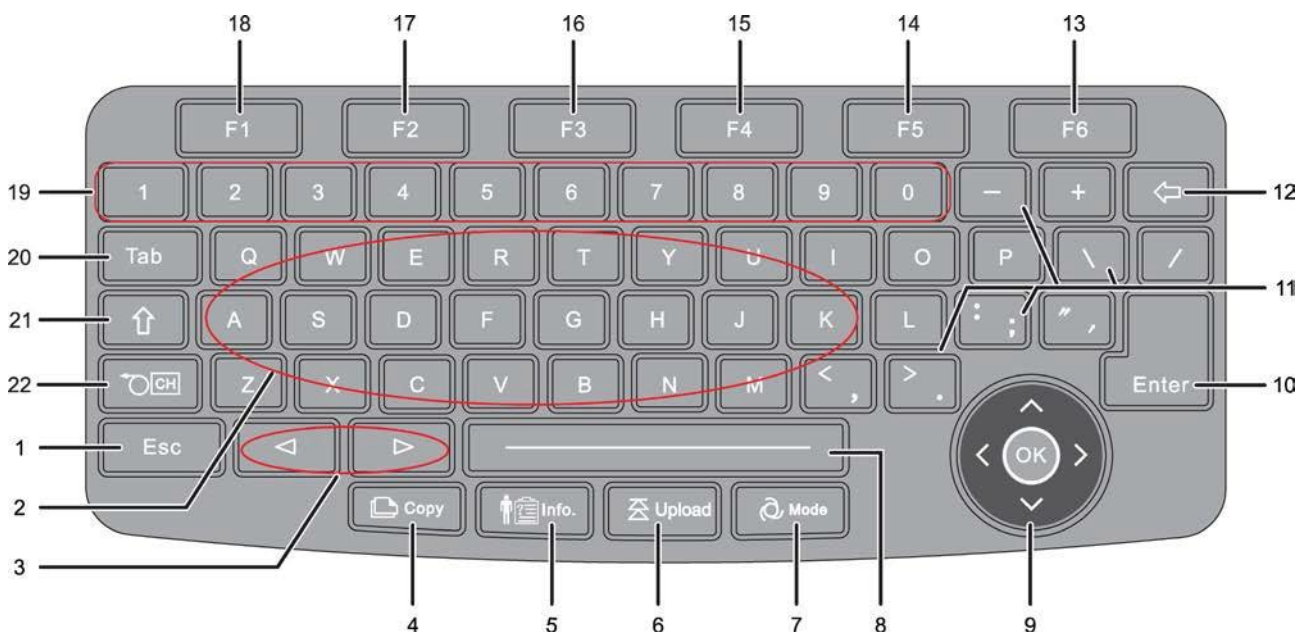











Figure 1-3 Keyboard

Number	Name	Description
1	Esc	Exit the current interface and go back to previous one.
2	Letter buttons	Input letters in text editing.
3	 	In manual mode, switch among different lead groups. In split-screen mode, switch among different screens.
4	 Copy	Copy the previous report in automatic recording mode.
5	 Info.	Input patient information.

6	 Upload	Upload files to the ECG management system on PC.
---	--	--

Number	Name	Description
7		Select a record mode and record format.
8	Space button	Input one or more spaces in the characters editing.
9		Press Up/Down/Right/Left button to select a menu or an option. Press [OK] to confirm, to open a submenu, or to toggle between two options in a submenu.
10	Enter	Press to confirm, to open a submenu, or to toggle between two options in a submenu.
11	Symbolic button	Input the character symbols in the input method.
12		Delete previous inputted character.
13	F6	On the Main interface, press to print the report. On the Data Management menu, press to turn to next page. In the Cycle recording mode and Trigger mode, press to start or pause monitoring.
14	F5	On the Main interface, press to select the Display Mode and Lead Format. On the Rhythm menu, press to analyze the ECG.
15	F4	On the Main interface, press to freeze the screen. On the Data Management menu, press to copy the files.
16	F3	On the Main interface, press to display ECG report. On the Data Management menu, press to upload the files.
17	F2	On the Main interface, press to display rhythm ECG. On the Data Management menu, press to upload the files.
18	F1	On the Main interface, press to enter the configuration menu. On the Data Management menu, press to open the files.
19	Numeric buttons	Input numbers.
20	Tab	Move the cursor.
21		Toggle between uppercase and lowercase letters.

22		Align the recording paper.
----	---	----------------------------

Patient Cable

We have two types of patient cables optional. Refer to Figure 1-4.

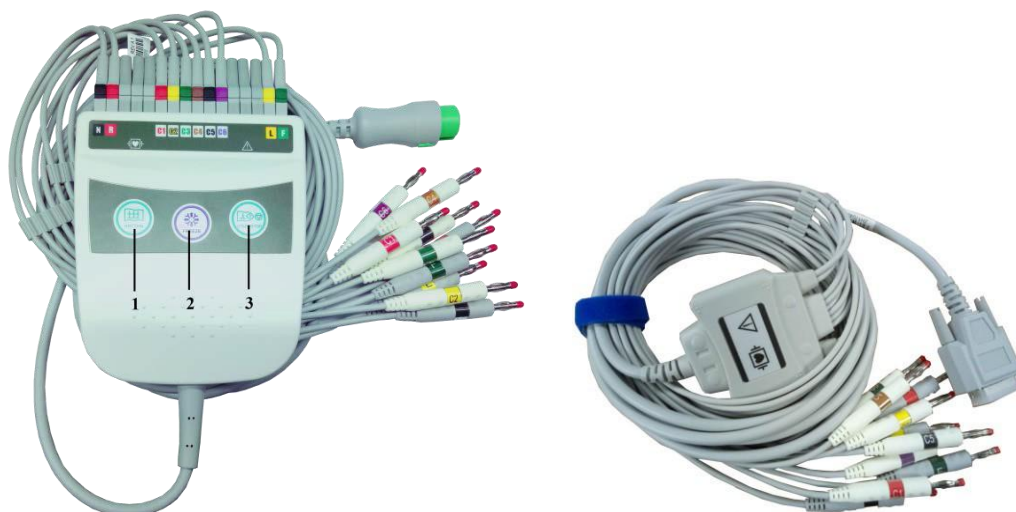

Figure 1- 4 Patient Cable

Number	Name	Description
1	Rhythm Mode Button	Start rhythm leads analysis
2	Freeze Button	Freeze the waveforms of previous 300 seconds. The user can select any waveforms in these 300 seconds to analyze and print.
3	Record/Stop Button	Start or stop recording the ECG.

Waveform Display

EXPLANATION

Screen display may slightly differ from the product you purchased, which will not affect your usage. Please operate according to the actual functions of the product.

In mode of same screen display, all the lead waveforms will be displayed on one interface.

In mode of split-screen display, all the lead waveforms will be displayed on several interfaces, which make it possible to show the waveform details more clearly.

Select **[Display]**, set the display format and lead format.

Same Screen Display

Waveform in same screen,
3x4 lead format:

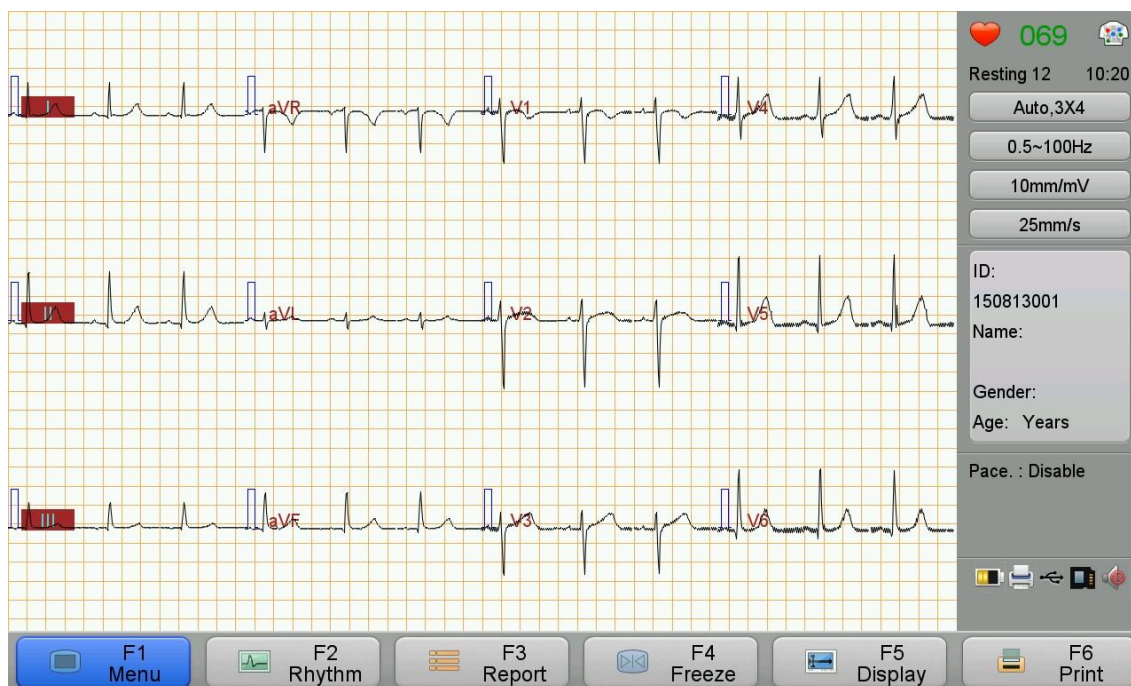

Figure 1- 5 Main Interface

Waveform under same screen, Waveform under same screen, 6x2+1 lead
format: 12x1 lead format:

I	V1	I
II	V2	II
III	V3	III
aVR	V4	aVR
aVL	V5	aVL
aVF	V6	aVF
II		V1
		V2
		V3
		V4
		V5
		V6

Waveforms will be displayed in the same way as that of the above figure in other lead formats of 12-lead. Please refer to appendix **Technical Specification** for details of lead formats.

Cabrera lead mode is available in this ECG machine, in which the leads order is aVL, I, -aVR, II, aVF, III, V1 to V6. -aVR is the opposite direction of aVR. In the menu **[ECG Setting]**, select **[Lead Mode]**; you can switch between "Standard Leads" and "Cabrera". Lead waveforms of Cabrera are shown as below:

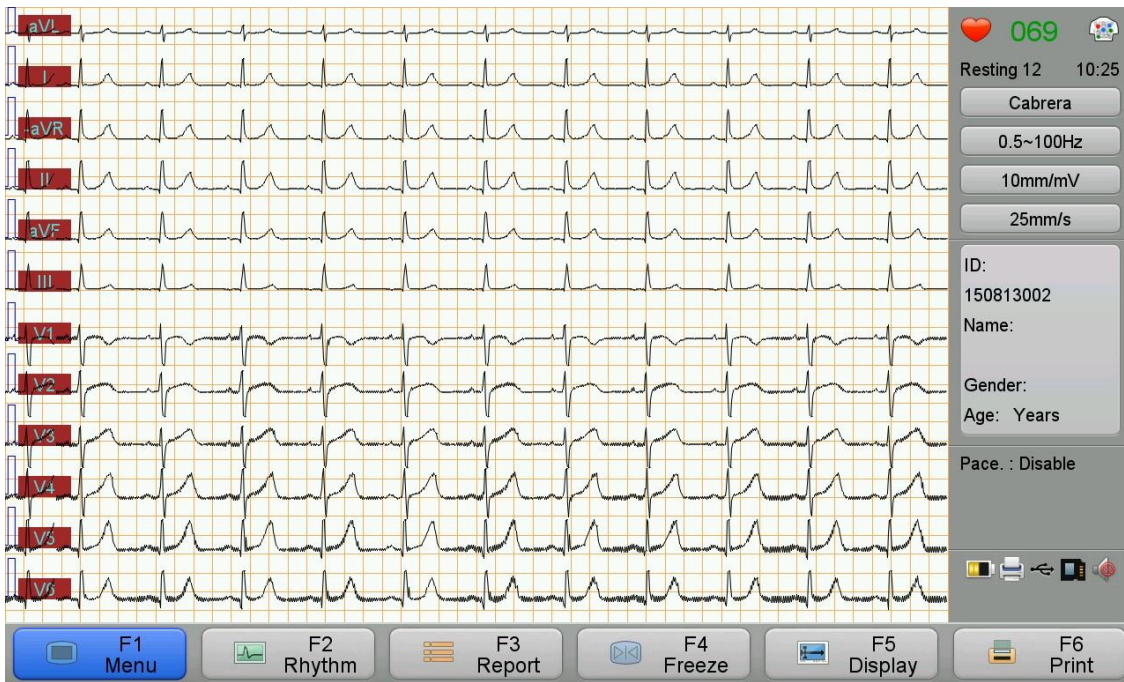

Figure 1- 6 Cabrera Mode

EXPLANATION

Waveforms cannot be split-screen displayed in Cabrera lead mode.

Split-screen Display

The split-screen lead formats of 12-lead ECG are 3x4 and 6x2. Waveform under split- screen, 6x2 lead format:

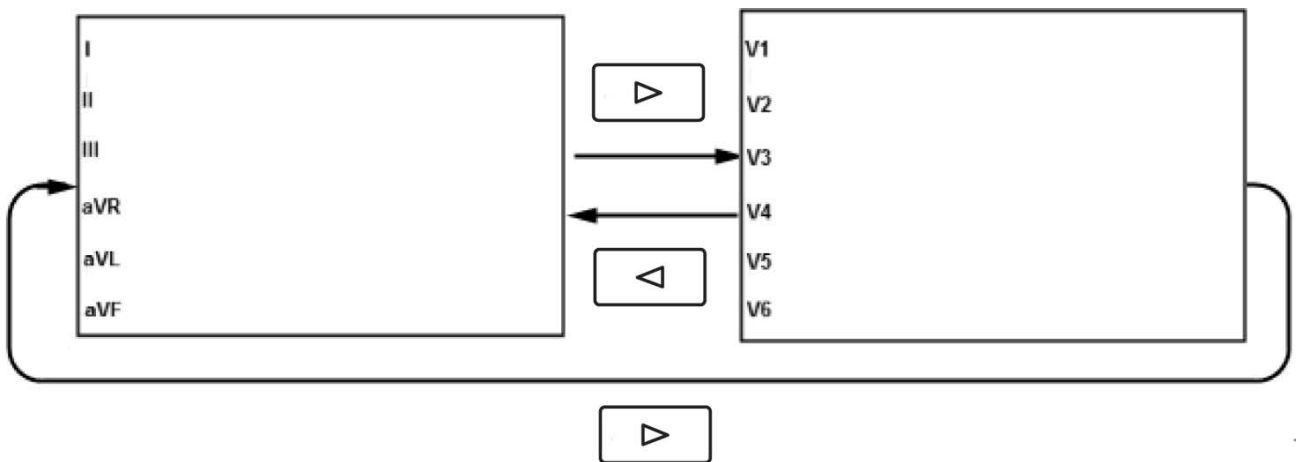

Figure 1- 7 Lead Switch

For the other lead format of 12-lead, please press



to change displayed waveforms.

Chapter 2 Preparing Recording

Location Selection

Please refer to the caution of foreword.

Load the Recording Paper

EXPLANATION

Installation of recording paper may slightly differ from the product you purchased, which will not affect your usage, please operate according to the actual functions of the product.

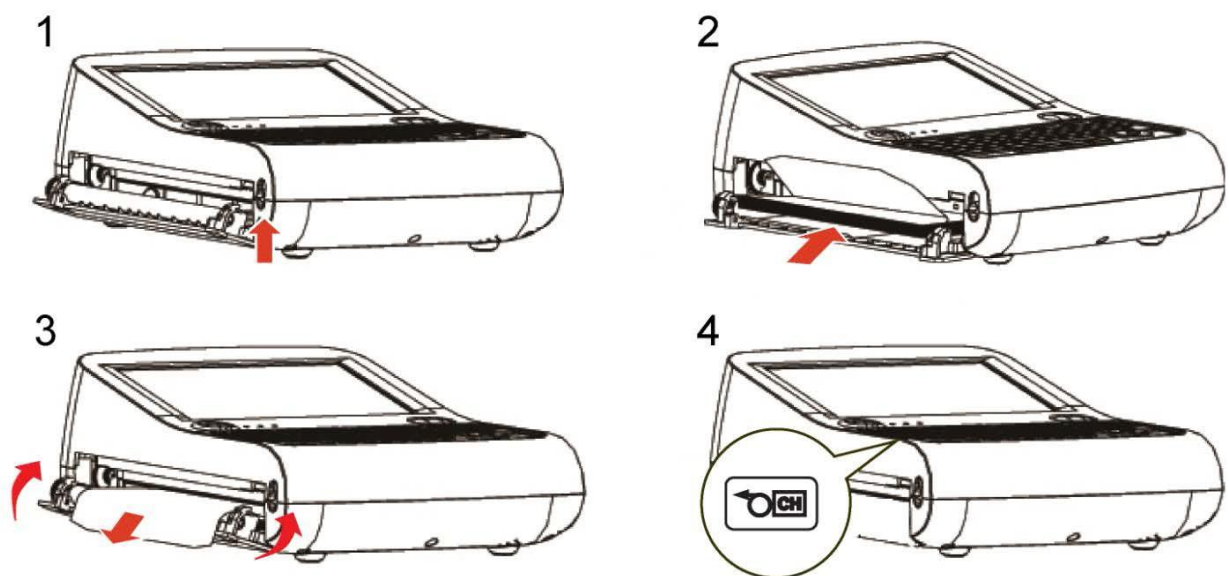

Figure 2- 1 Load the Recording Paper

Push the button upwards. The Paper tray opens.

Insert the recording paper fitly into the Paper tray with the grid upwards and the black mark towards the Paper tray.

Pull out the paper about 2cm and press both sides of the Paper tray to close.

And then press 

CAUTION

Do not use other type of recording paper except 210 mm×150 mm Z-fold paper (Enclosed).

Please make sure recording paper is installed fitly and straightly, otherwise paper may be stuck.

If there is no paper, or the paper has been used up, or the paper was not placed well, the alarm will appear on the main screen and the machine will not print.

Power Supply Connection

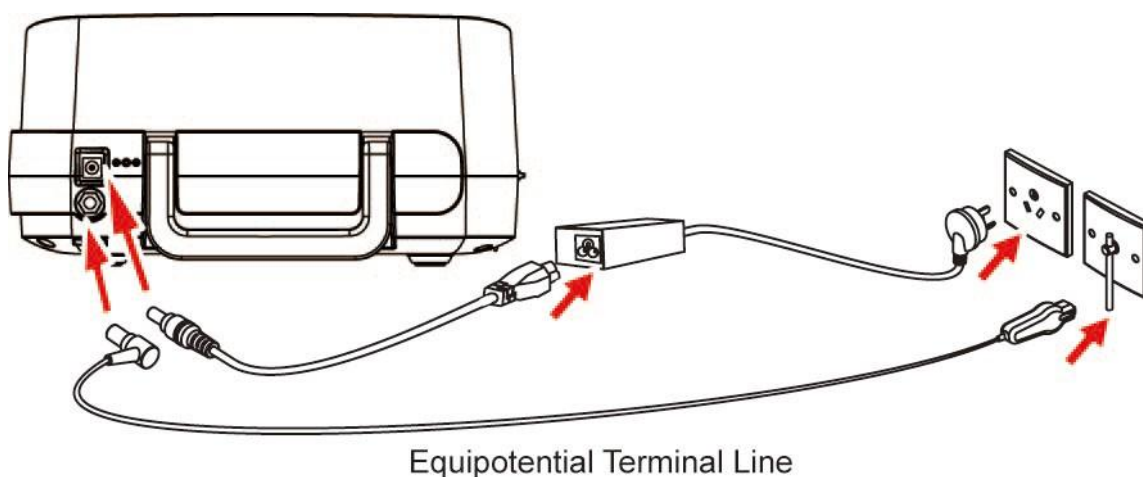

Figure 2- 2 Connect to AC Power Supply

Plug the AC power cable and equipotential line into the ECG machine.

Connect power adaptor with the power outlet, and connect equipotential cable with equipotential terminal in the room.

EXPLANATION

The ECG machine is equipped with a built-in rechargeable battery. Please check the battery capacity before using the battery for power supply.

CAUTION

When the ECG machine is operated together with other medical equipment, please use the accompanying

equipotential cable and connect the equipotential terminal of the ECG machine altogether with that of the other equipments so as to protect the patient from possible electric shock due to current leakage from those equipments. Equipotential cable must be connected between the equipotential terminal of the ECG machine and the room. Do not connect the equipotential cable to a conductive water pipe or the other pipes. Otherwise it may cause electric shock hazard to the patients.

Patient Cable Connection

We have two types of patient cable sockets optional. Refer to Figure 2-3.

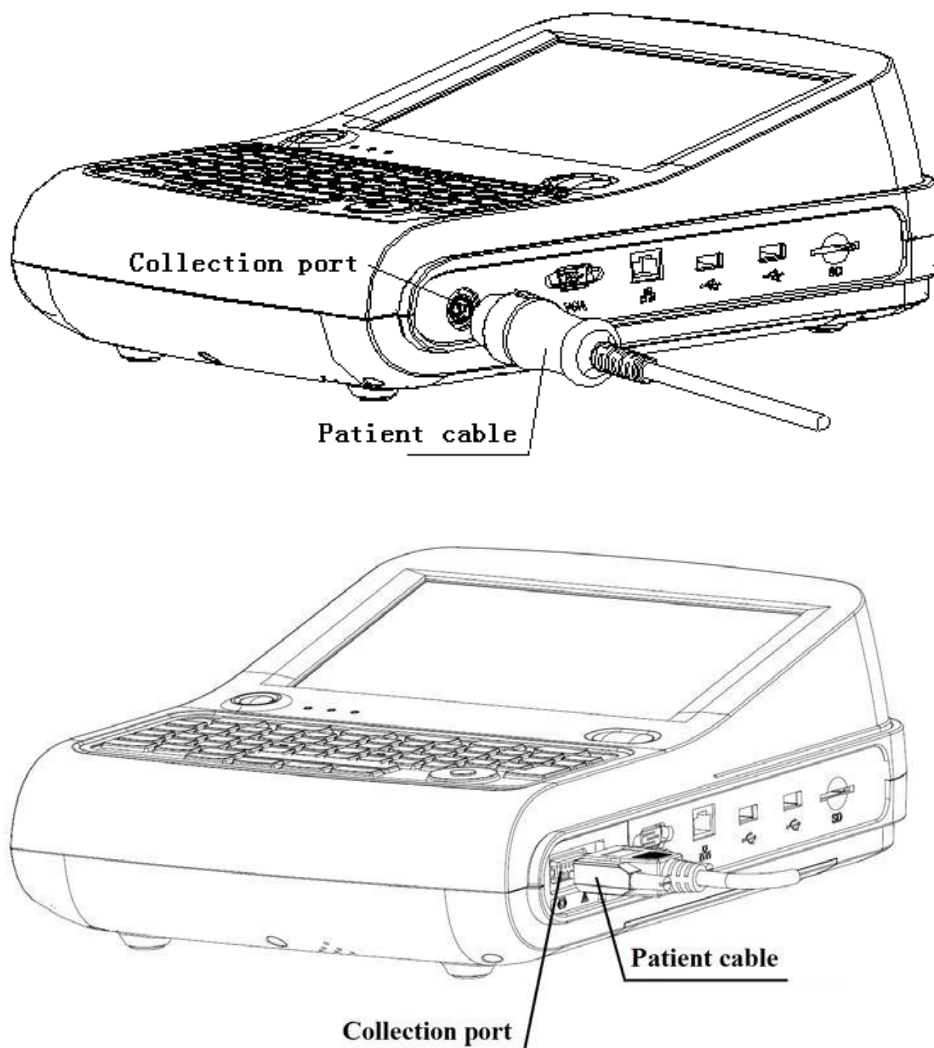

Figure 2- 3 Connect to Patient Cable

CAUTION

Do not use any other types of patient cable except the supplied one. The patient cable socket is exclusively used for connecting the patient cable. Please do not use it for other purposes.

Insert or Remove an SD card

Insert an SD card

Push to insert an SD card into the SD card slot until a “clicking” sound.

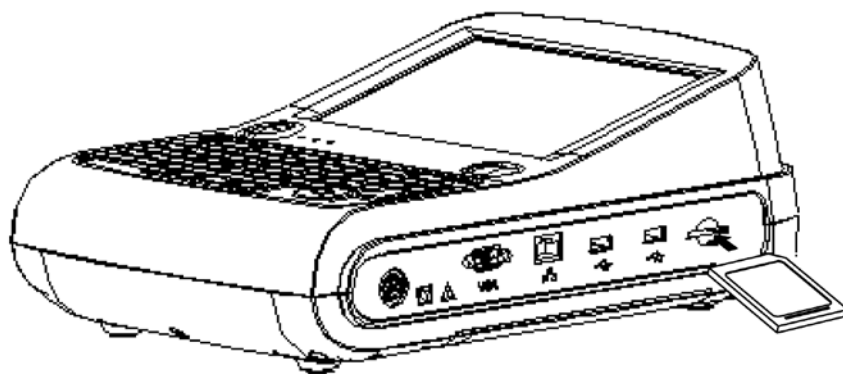

Figure 2- 4 Insert the SD Card

Remove an SD Card

Push the SD card forward gently until a “clicking” sound.

Release the SD card, and then SD card eject about 5 mm.

Pinch the SD card away from the slot.

CAUTION

If resistance happens when inserting SD card, check whether there is foreign bodies in the slot or the direction of SD card is correct. Do not throw or bend the SD card, or it may be broken.

Power On/Off



Press  to power on/off the ECG machine.

The ECG machine enters standby mode if it is not in use for a time duration.

Set the time duration in **[System Setting] > [Standby Time]**. Press any key or touch the screen to exit standby mode.

The ECG machine will shut down automatically if it is not in use for time duration. Set the time duration in

[System Setting] > [Auto Power Off].

EXPLANATION

The ECG machine will not enter standby and auto power off in Trigger mode and Cycle recording mode.

Network Connection

EXPLANATION

The machines include standalone version and network version. Only network version machines are equipped with network features. If network features are needed, please contact our customer service.

In the ECG machine of network version, network connection may slightly differ from the product you purchased, which will not affect your usage, please operate according to the actual functions of the product.

In order to realize the data transmission, you need to install ECG management system software and drivers on the computer (Please refer to the user manual of ECG management system. If ECG management system is needed, please contact our customer service.)

CAUTION

In the data transmission, if the ECG machine warns "Network connecting failed", please reset the network.

Connect to a Wired Network

As shown in the following figure, the cable network system is composed of the ECG machine, the switchboard and the server.

Go to **[Menu] > [System Setting]**. Tap **[Transfer Protocol]** and set according to the protocol of the server. Two options are: TCP and FTP.

Tap **[Cable Network]** and set the **[IP address]**, **[Subnet Mask]** and **[Default Gateway]** of the ECG machine. If the IP address is within the same network segment of the server, the subnet mask and gateway shall be as the set value of the server. If the IP address is not within the same network segment of the server, subnet mask and gateway of the **[Cable Network]** shall be set according to actual situations, but make sure the specified gateway do support the data transmission between the two network segments.

Tap **[Server Setting]** and set the **[IP address]** and **[Port]** number of the server.

When the cable network is connected successfully and able to communicate with

the server, the Main interface will display the icon .

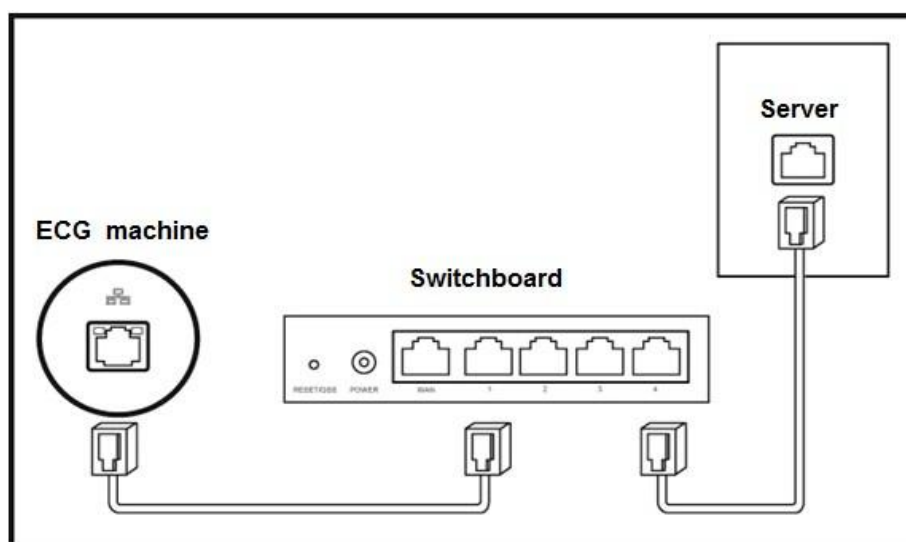

Figure 2- 5 Cable Network Connection

Connect to a Wireless Network (Optional)

As is shown in the following figure, the wireless network system is composed of the wireless AP on the ECG machine, the switchboard and the server.

Go to **[Menu] > [System Setting]**. Tap **[Transfer Protocol]** and set according to the protocol of the server.

Two options are: TCP and FTP.

Set the SSID and password (can be set at will) of the wireless AP and use automatic channel if there is no special requirement.

Set the IP address and port number in the menu **[Server Setting]** as the IP address and port number of the server.

Set the SSID, password and Security in **[WIFI Network]** to the set value and type of the wireless AP. The encryption method should be set up according to that of wireless AP.

In **[WIFI Network]**, the setting of the DHCP service can be enabled or disabled according to the requirement. When DHCP service is enabled, it is unnecessary to set IP address, subnet mask and gateway manually. When it is disabled, it is necessary to set IP address, subnet mask and gateway with respect to the setting mode of wired network.

After WIFI network is connected, the system interface will display the icon .

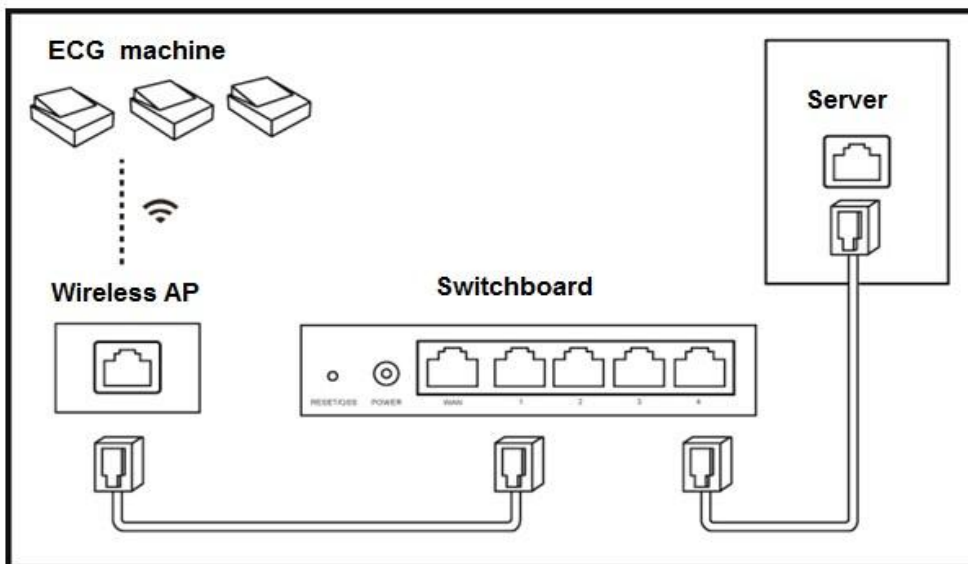

Figure 2- 6 Wireless Network Connection

Apply Electrodes

Before attaching the electrodes to patient, wipe skin oil off by using medical alcohol to all the positions where electrodes are to be attached, and then apply ECG gel on the skin. After that, place electrodes to the right position. If using the vacuum ball electrodes, you should apply ECG gel on the electrodes, and then pinch the suction ball to make sure the electrodes contact with skin tightly.

⚠ CAUTION

Proper electrode attachment is vital for obtaining accurate ECG waveforms; therefore, please ensure good contact between the skin and electrodes. Do not use the new electrodes and the used ones at the same time. Replace all electrodes together when any one of them is supposed to be replaced. Do not use disposable electrodes more than one time.

Confirm the disposable electrodes are within the valid period.

Use the disposable electrodes as soon as possible after opening the package (generally within 7 days).

Electrodes or conducting point of patient cable shall not be in contacting with any other metal part or conductor. Avoid the electrodes to be dragged by the lead wires.

Make sure the patient's skin contacted with the electrodes has been well pretreated.

Clean the stain on the electrodes with medical alcohol whenever the electrodes are contaminated.

Make sure metal electrodes of limb electrodes touch fully with skin and tightly enough.

Make sure adjacent electrodes and ECG gel, especially chest ones, are not contacted with each other.

If the examinations involve a short period of time, if ECG gel is unavailable, please wipe the skin with medical alcohol to keep the skin clean and moist, and then rapidly attach the electrodes.

It's not allowed to use saline water as substitute to ECG gel. The saline water will cause corrosion on the electrodes.

For chest and back application of pediatric, disposable electrodes are suggested.

Electrodes shall be properly stored. When electrodes have been used for a certain period, they may become corroded and oxidized at the surface.

Whenever this happens, the electrodes must be replaced.

Do not mix electrodes of different types and manufacturers. Do not use re-useable electrodes and disposable ones together, or it will affect the recording. Please use our company's or authorized electrodes to make sure qualified ECG.

Electrodes Attachment

Limb Electrodes Placement				
	IEC	AHA	Description	Figure
	R Red	RA White	Right Arm	
	L Yellow	LA Black	Left Arm	
	N Black	RL Green	Right Leg	
	F Green	LL Red	Left leg	
Standard 12-lead				
	IEC	AHA	Description	Figure
A	C1 Red	V1 Red	Fourth intercostal space at right sternal border.	
B	C2 Yellow	V2 Yellow	Fourth intercostal space at left sternal border.	
C	C3 Green	V3 Green	Equidistant between B and D	
D	C4 Brown	V4 Blue	Fifth inter-costal space at left mid-clavicles line	
E	C5 Black	V5 Orange	Left anterior auxiliary line at the horizontal level of D	
F	C6 Purple	V6 Purple	Left mid-auxiliary line at the horizontal level of D	

Lead Signals Formation Scheme

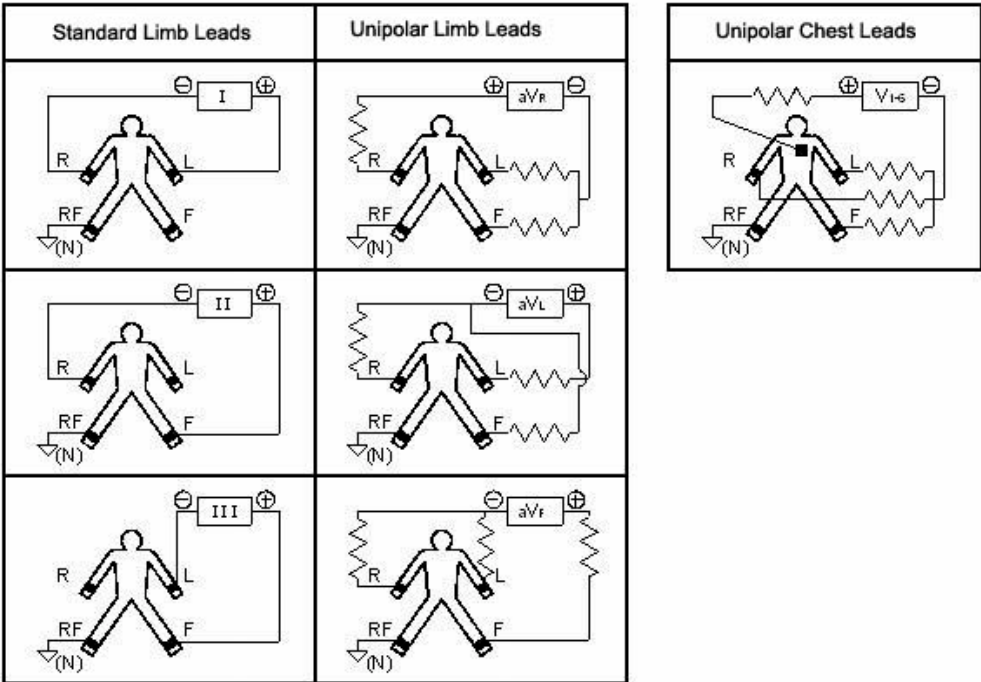
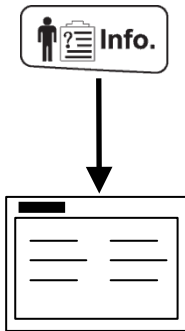

Figure 2- 7 Lead Connection

Chapter 3 Entering Patient Information

1 Enter Patient Information



Entering patient information

You can enter patient name, gender, ID Number, etc through the way mentioned above. Refer to **Patient Information** to get more details.

Inputting ID number

Automatic Coding: ID code is automatically generated by the system when admitting a new patient and an ID code will be automatically increased each time you press OK button.

Manual Coding: You can input numbers and letters according to own demand.

Barcode Scanner: You can scan the bar code directly using the scanner to generate ID code. Select "ID Number" and perform a scan to generate the ID code.



Figure 3- 1 Barcode Scanning

EXPLANATION

When Barcode Scanner is selected as the input mode, the soft keyboard will not pop. For the usage of the barcode scanner, please refer to the user manual of barcode scanner.

CAUTION

Improper patient information may cause misdiagnosis. Please check the information for each new patient.

Please avoid the same ID number for two patients. Otherwise, it may cause file lost or file mistake.

Introduction of Input Method

You can input through either software keyboard or physical keyboard. The software keyboard on the interface is as following:

Standard Character Keyboard

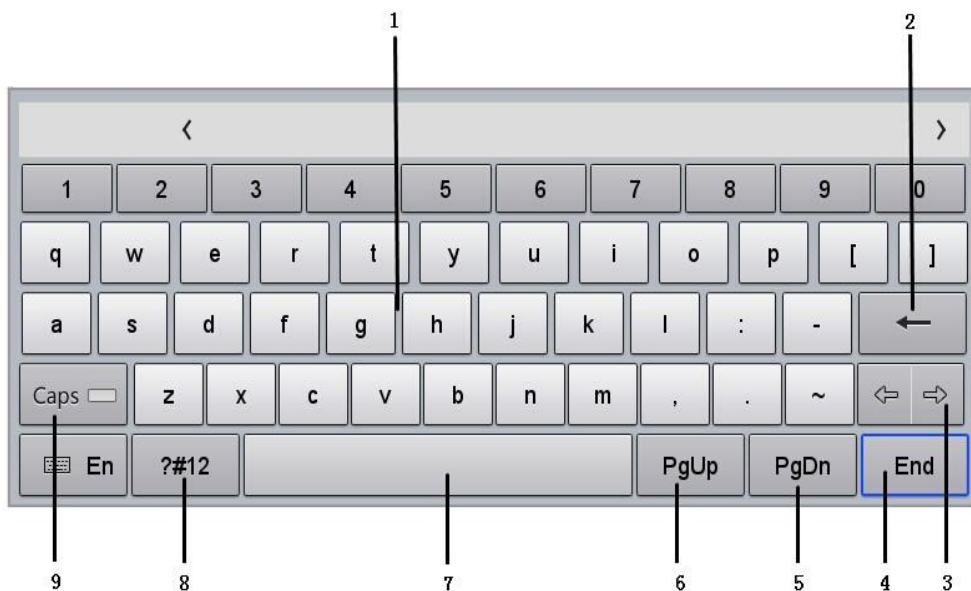

Figure 3- 2 Standard Character Keyboard

Number	Name	Description
1	Characters Area	Input letters or punctuations.
2	Delete	Delete previous inputted character.
3	Cursor Moving	Move the position of cursor on the interface.
4	End	Confirm the current input.
5	Page Down	/
6	Page Up	
7	Space	Input null characters.
8	Symbols	Switch to symbols pad to input kinds of symbols.
9	Caps	Switch between uppercase and lowercase letters inputting.

Digital Keyboard

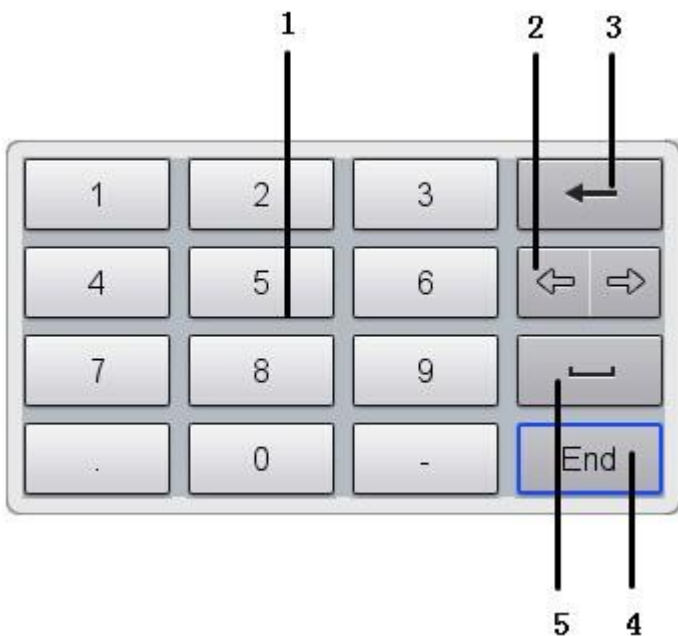

Figure 3- 3 Digital Keyboard

Number	Name	Description
1	Characters Area	Input numbers or punctuations.
2	Cursor Moving	Move the position of cursor on the interface.

3	Delete	Delete previous inputted character.
---	--------	-------------------------------------

Number	Name	Description
4	End	Confirm the current input.
5	Space	Input null characters.

Chapter 4 ECG Recording

After the ECG machine has been powered on and all the leads are well connected, the following main interface will display. And the ECG machine is ready for recording.

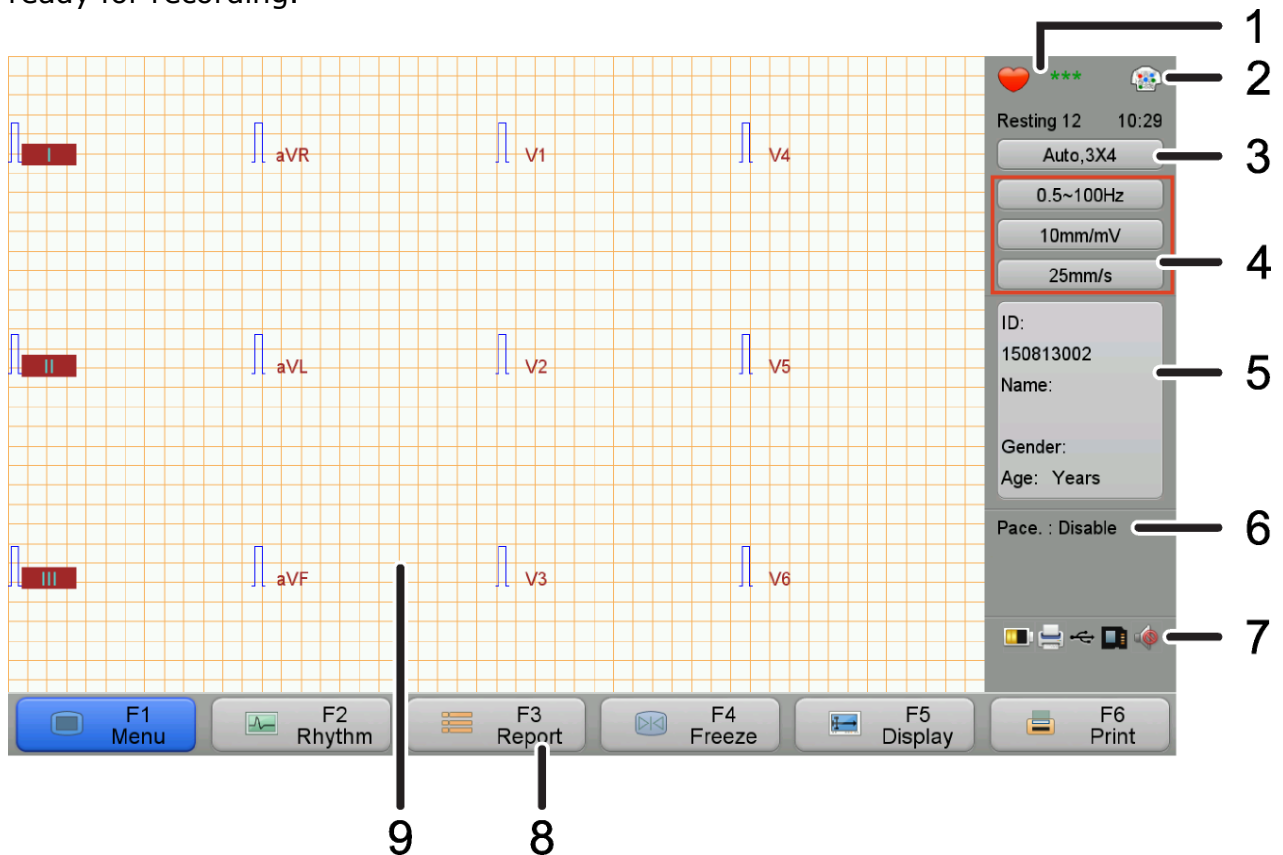

Figure 4 - 1 Main Interface

Number	Name	Description
1	Heart Rate Icon	Display patient's heart rate.
2	Lead Status	Display the location and state of the electrode in the human body. Selected for a larger view. If the lead wires are not connected properly, such as electrode falls off, the corresponding electrodes on the view will flash to alarm.
3	Record Setting	Display Record Mode and Record Format. Click to select other mode and format.
4	ECG Setting	Display current Filter, Gain and Print speed.

5	Patient Information	Display Patient Information. Click it to input other patient information.
6	Alarm Area	Display text alarm information, including system failure about patient cable/Print head/Paper, lead off, AC interference, EMG interference, baseline wander, and data overflow, etc.
7	System Status	Indicates system status, for example, mute, recording, network, SD card <i>inside USB connecting battery etc.</i>
8	Shortcut Keys	Quick operation to set up parameters and execute functions.
9	Waveform Display	Display real time waveforms.

EXPLANATION

Main interface may slightly differ from the product you purchased, which will not affect your usage, please operate according to the actual functions of the product.

Introduction of Sensitivities, Filters, and Print Speed

Before printing, it is necessary to do the following parameter setting: On the

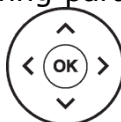

main interface, tap directly to select or press to select below three options in the red rectangle.

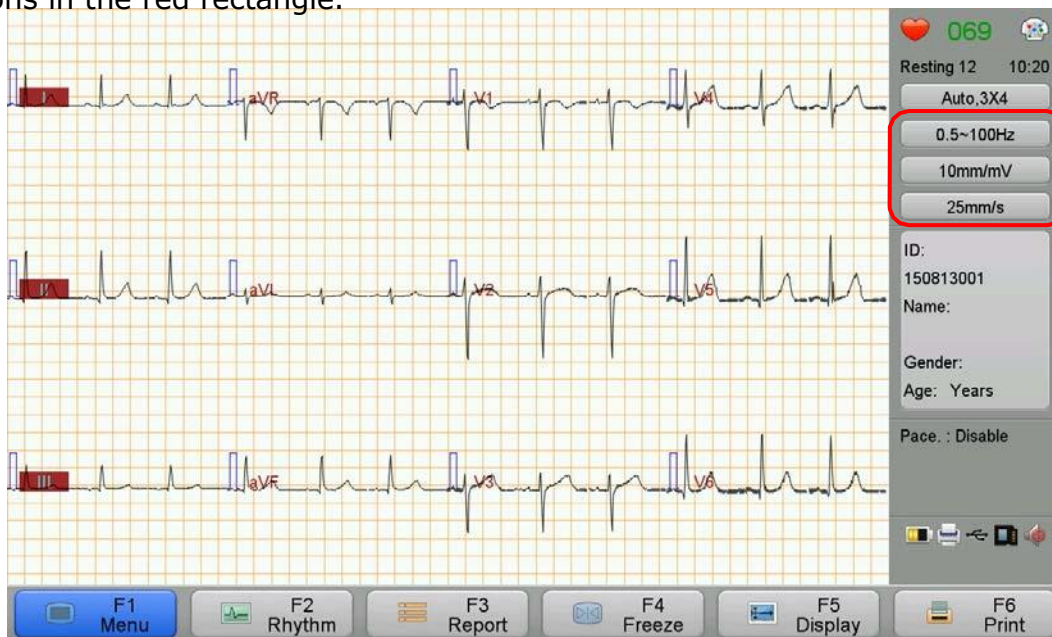

Figure 4- 2 Setup of the Sensitivities, Filters, and Print Speed

0.5-100Hz : Set the Low-pass Filter, Baseline Wander Filter and AC Filter.

10 mm/mV
: Set the sensitivities.

25 mm/s
: Set the Print Speed.

EXPLANATION

A sort of noise may degrade the collected ECG signal. You can select a set of filters to optimize the displayed or printed ECG waveforms.

By setting different low-pass filters, the QRS wave group's amplitude, time limit and form may change.

By setting different baseline wander filters, the form of ST segment may change.

Filters settings will not affect the algorithm analysis.

In order to reduce baseline wander, a baseline wander filter should be employed. To make sure the ST segment is not distorted, the AAMI standards recommend that cut-off frequency of the baseline wander filter is lower than 0.67Hz.

Record an ECG

EXPLANATION

The Pre-acquisition mode is valid only in automatic recording mode. When the Pre-acquisition mode is on,

the waveforms printed and uploaded are that before pressing  to start, while if the Pre-acquisition mode is off, the printed wave form is that after

pressing  to start.

[Record Format] is a waveform pattern traced on the recording paper. Please see **Technical Specification**

for specific recording formats.

For ECG type of Resting 12, if **[Cabrera]** is selected, the **[Record Mode]** is the automatic recording mode, and **[Record Format]** is a fixed format.

[Synchronous] and **[Real Time]** are activated only when waveforms are printed in more than one column.

[Synchronous]: the starting time of all waveforms are the same;

[Real-time]: the starting time in different columns is different, and the starting time of one column is

sequential to the ending time of the previous column. Set them in [Print Setting] > [Print Data Type].

If you have blank paper, select **[Print Setting] > [Print Grid] > [Enable]** to print the ECG showing the grid. If you have paper with grid, suggest selecting **[Disable]** to print the ECG without showing the grid.

 **CAUTION**

When copying or moving the files, it is not allowed to plug or unplug the USB device or SD card; otherwise, it may cause abnormality of the ECG machine.

Main Operation Process to Record ECG

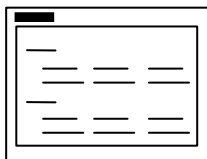

Set the Record Mode and Record Format



Observe the waveforms displayed

Normal Abnormal (Lead off, data overflow and etc)

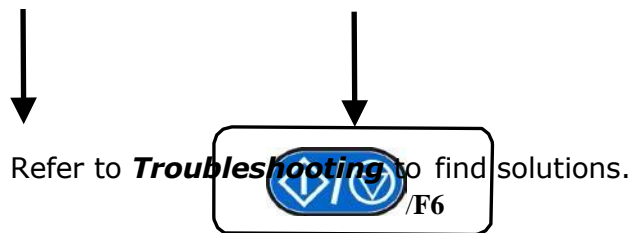

Recording an ECG

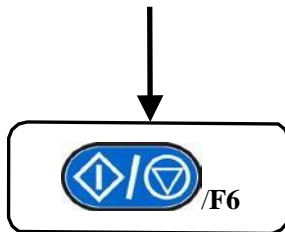

Exit the recording

When the recording is about to finish (under any recording mode except manual mode), the system will perform a resting ECG analysis automatically. For more details, please refer to **Automatic Recording Mode**.

Arrhythmia Detection

If **[Arrhythmia Mode]** in **[ECG Setting]** is set to enable, when arrhythmia is detected, rhythm waveforms can be printed manually as following:

Recording waveforms and report

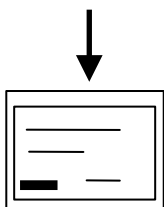

Arrhythmia is detected.
Print the rhythm waveforms?



Print rhythm waveforms Return to the main interface

Waveforms length is based on "Rhythm Time", please refer to ***Rhythm Mode***.

EXPLANATION

Arrhythmia can only be detected in Automatic mode, Economic mode and Cycle mode.

Please refer to ***Introduction of Sensitivity, Filter, and Paper Speed*** to set these parameters before printing.

Please refer to ***Troubleshooting*** to understand how to avoid abnormal waveform recording, for example interference.

CAUTION

After the heart rate and waveforms become stable, you can print out the ECG waveforms together with a resting ECG analysis.
When the patient wears a pacemaker, the low-pass filter should be set to >150 Hz.

In sequence to prevent the pacemaker from being detected repeatedly or omitted, you should set the detection sensitivity according to the actual clinical need. Sensitivity can be set in **[Pacemaker Detection]** of **[ECG Setting]**. This ECG machine can detect the lead connecting status continuously, and if any leadoff is detected, the corresponding lead code will be displayed in the Alarm Area on the main interface, accompanied by sound alarm. When "Lead off" continues, please check carefully from skin to the ECG machine (including electrodes, lead wires and acquisition module). Alarm will disappear when connections become reliable.

Introduction of Record Mode

EXPLANATION

Waveform length to be printed and uploaded is set in **[Wave Sample Time]** of **[ECG Setting]**.

In **[ECG Setting]**, if **[Auto Upload]** is enabled, the ECG machine will automatically upload the waveforms and the reports after printing the waveforms.

In **[ECG Setting]**, if **[Auto-save]** is enabled, the ECG machine will automatically store the waveforms and reports after printing the waveforms.

If the waveform and the report need to be stored in a specified memory, you should go to **[System Setting] > [Default Memory]** and select the desired memory: Internal Memory, USB Flash Drive or SD Card.

Economic Recording Mode

In Economic mode, all the waveforms and analysis results are designed to be printed on A4 size thermal paper, so that recording can save the paper costs.

EXPLANATION

In Economic mode, only **Simple Report** can be printed, **Detail Report** and **Median Beat Report** are not supported.

To save paper, The ECG machine only print waveforms of 10 seconds.

Automatic Recording Mode

In Automatic mode, the ECG machine can automatically print the waveforms and reports according to **[Report Format]** in **[Print Setting]**.

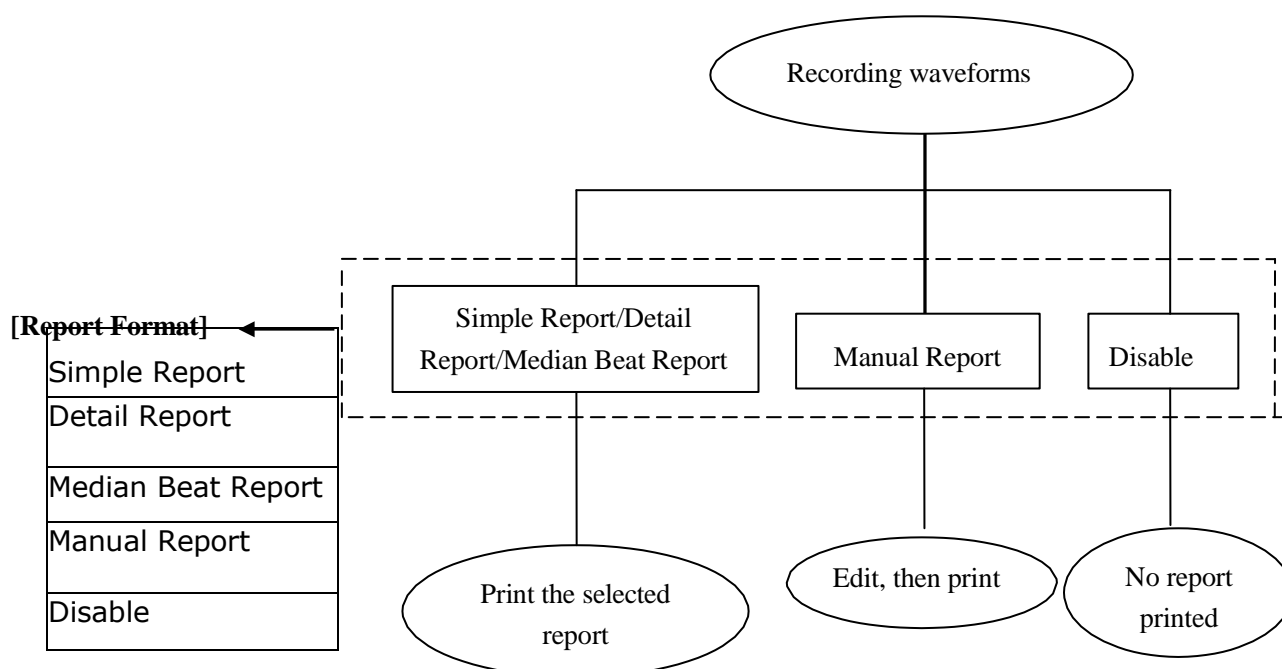

The ECG machine can analyze the resting ECG and output the measurement data, median Beat and analysis result, etc.

Simple Report includes patient information, simple measurement data and Minnesota code;

Detail Report includes patient information, simple measurement data, Minnesota code and detailed measurement data;

Median Beat Report includes patient information, simple measurement data, Minnesota code, Median Beat waveform and Rhythm waveforms.

In Manual Report mode, the analysis reports include analysis report (1), analysis report (2) and analysis report (3). In **[Print Setting]**, when **[Analysis Output]** is enabled, all the above-mentioned reports will include the analysis results.

Auto Print

In Economic mode and Automatic mode, select **[Menu] > [Print Setting] > [Auto Print] > [Enable]**, the ECG machine will automatically print the waveforms and reports when the following 3 conditions are satisfied.

Lead off does not detected for 2s (none of any electrodes);

Five or more QRS complex detected;

Waveform is stable, no EMG interference or Baseline drift.

EXPLANATION

The resting ECG only analyzes the latest 10-second waveforms.

If the age is not inputted, the ECG machine will analyze the data assuming the patient is an adult.

WARNING

In the case for some special populations (such as pregnant women, the user of vascular drugs, etc.) or mixed by obvious interference in the recording process, the analysis result may be inaccurate. Therefore the final conclusion should be drawn by a doctor, based on analysis result, the clinical characterization of patients and other diagnostic test results.

If there is too much AC and EMG interference, the identification of P wave and Q wave is not reliable sometimes; if there is baseline wander, the identification of ST segment and T wave is not reliable sometimes.

If the ending points of S wave and T wave are winding and not clear, it might cause measurement error.

If R wave is undetected because of low voltage for QRS complex, it might cause some deviations in heart



rate measurement.

If QRS complex has low voltage, the electrical axis measurement and the identification of QRS dividing point can be unreliable.

Occasionally, the frequent (repetitive) ventricular premature beat might be detected as the median beat.

When several kinds of arrhythmia occur simultaneously, the identification of P wave might be difficult, and the relative parameters might be unreliable.

Manual Recording Mode

In Manual mode, press  to start or stop printing. You can switch from one column to another by pressing   at any time and to control the waveform length of every leads. In Manual mode, the ECG machine will not analyze or measure the acquired waveforms.

Cycle Recording Mode

In Cycle recording mode, the ECG machine will count down according to "Cycle Time", record the ECG waveforms automatically and periodically according to "Cycle Interval", until the end of time. Please refer to **Print Setting**.

EXPLANATION

After being set, the cycle recording mode will not take effect immediately until press .

Trigger Mode

In Trigger mode, when there is an arrhythmia, the ECG machine can automatically detect it and trigger the printing of waveforms and analysis report. After printing, the ECG monitor will wait until you confirm whether to continue the monitoring or not.

EXPLANATION

After being set, the Trigger mode will not take effect immediately until pressing .

Upload Mode

In upload mode, select **[Upload]** or press , the ECG machine will enter into analysis. After analysis, the ECG machine will upload the waveforms and reports to ECG workstation. During the process, no printing happens.

Advanced Mode

Rhythm Mode

Operate as follows to enter the rhythm mode:

Main interface

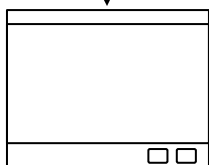
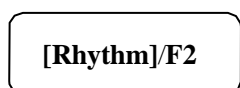

Enter rhythm interface

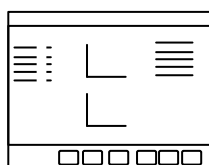

Enter rhythm report interface automatically

After entering rhythm interface, the ECG machine begins collecting waveforms of the Rhythm Leads. You can select single-rhythm or three-rhythm pattern. In Single-rhythm pattern, only one lead is selected as rhythm lead and as long as 300s waveform will be collected and analyzed. In Three-rhythm pattern, waveforms of three leads will be collected and analyzed, as long as 100s for each lead, totally 300s. After collecting, the ECG machine will automatically analyze the waveforms and enter Rhythm report interface.

In Rhythm report interface, you can select to **Print**, **Save**, and **Upload** the report and press **[Pageup]** and

[Pagedown] to review more information.

Please refer to *ECG Setting* to set **[Rhythm Mode]**, **[Rhythm Lead]** and **[Rhythm Time]**.

EXPLANATION

During the waveform collecting, you can tap **[R-R]** or press **F5** to enter Rhythm report interface manually when the collecting time is last more than 8 seconds.

Analysis Report Mode

12-lead ECG

Operate as follows to enter analysis report mode:

Main interface

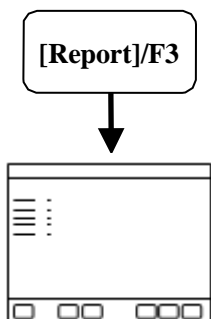

Enter analysis report

Report (1) includes simple measurement data, Minnesota code, median beat waveforms, analysis result and rhythm waveforms.

Report (2) includes detailed measurement data. Report (3) includes waveforms of all the leads.

Analysis report interface is as following:

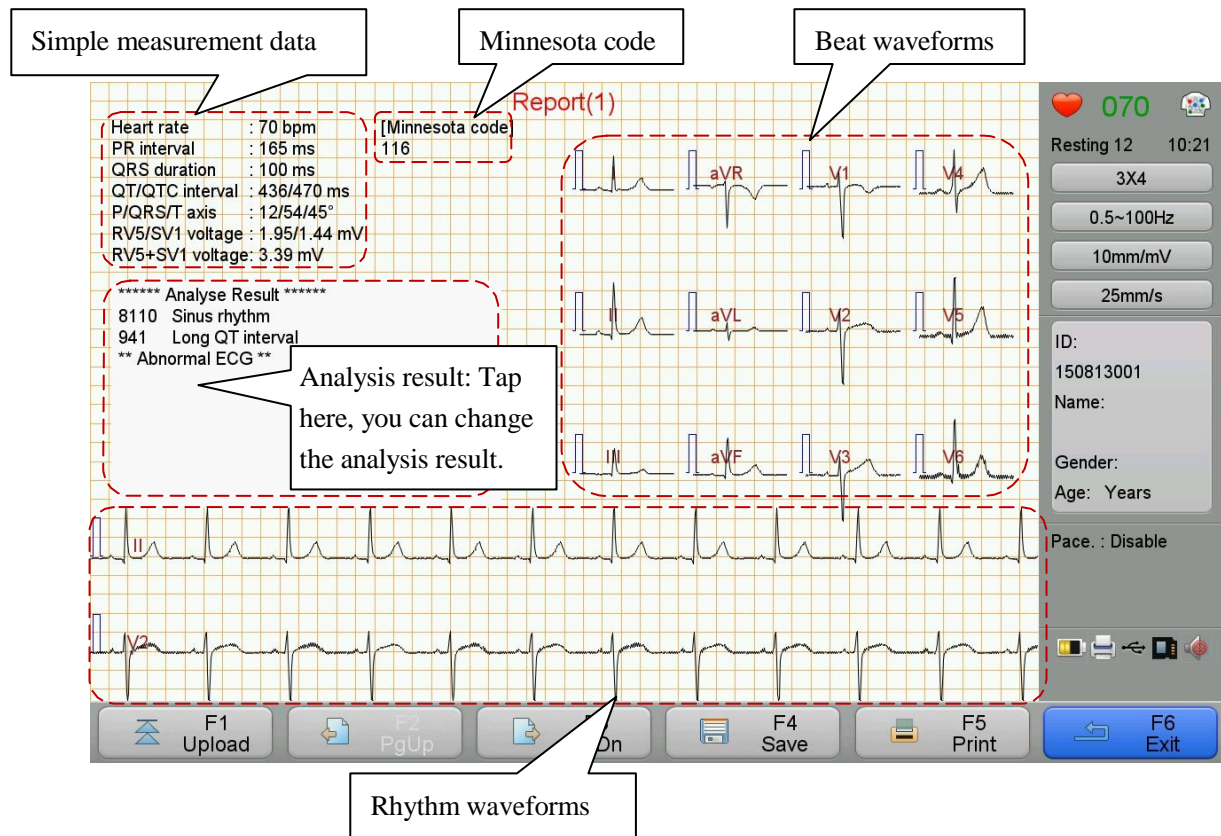

Figure 4- 3 Analysis Report 1

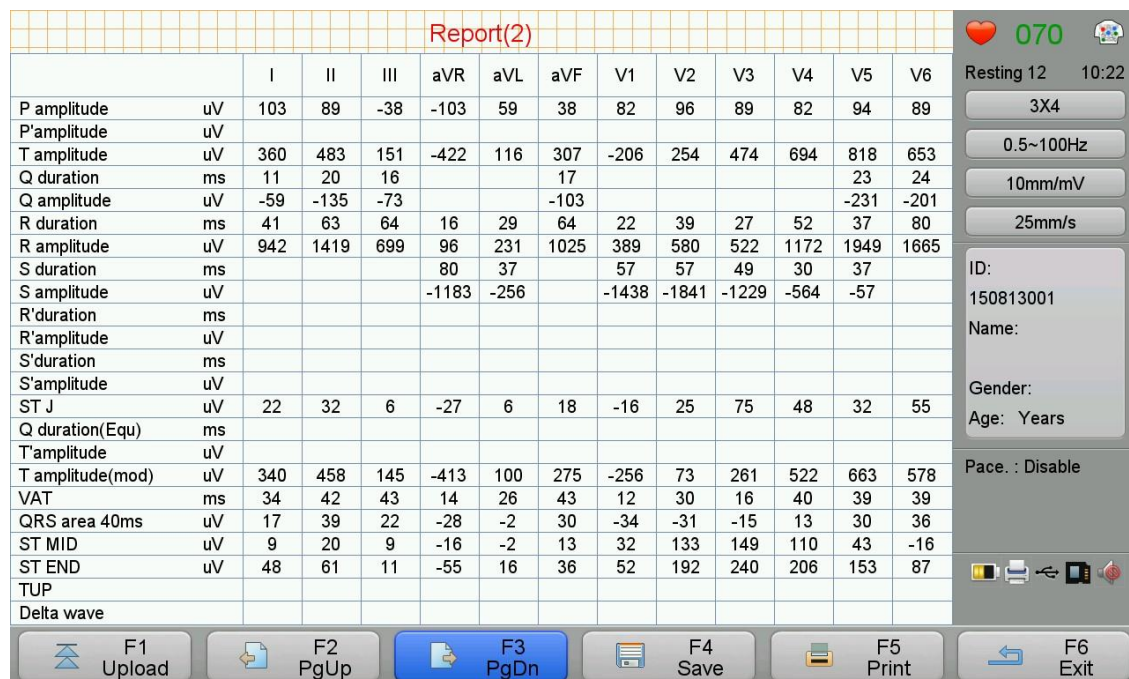

Figure 4- 4 Analysis Report 2

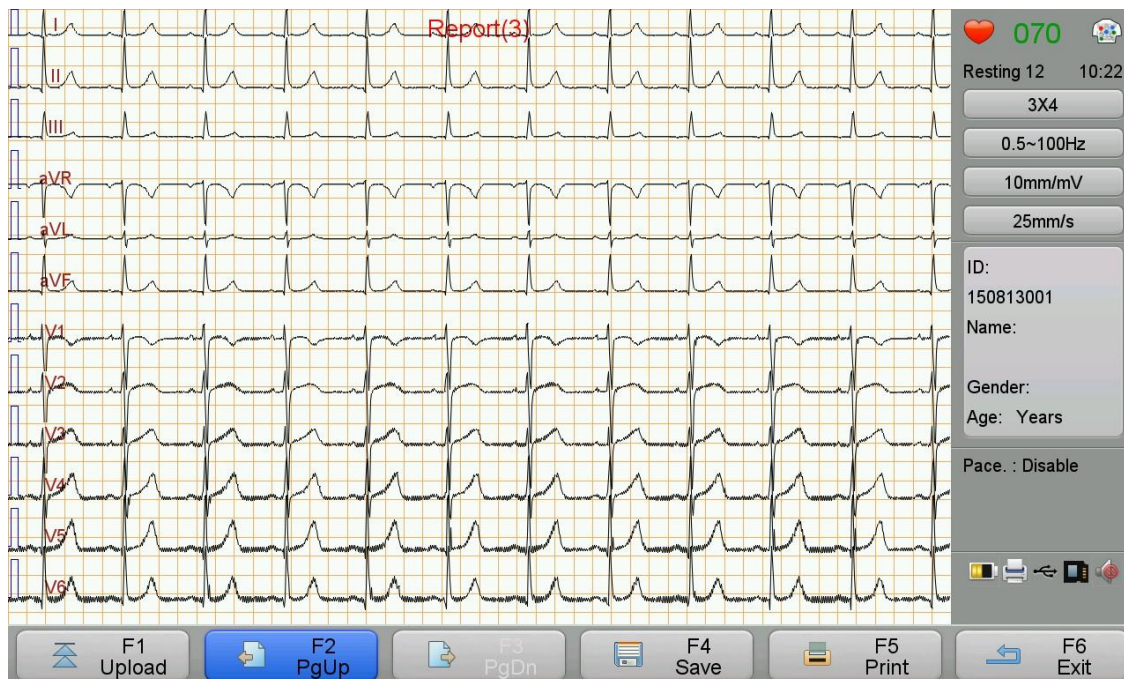

Figure 4- 5 Analysis Report 3

In the above three interfaces, you can select to **Upload**, **Save**, and **Print** the report. In analysis report (1), "Analysis Result" can be manually edited by the user. Please refer to **List of Interpretation codes and Corresponding Description** for the details of analysis result.

Freeze Mode

Operate as follows to enter Freeze mode:

Main interface

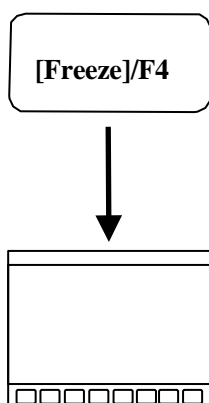

Enter freeze interface

You can freeze waveforms for 300s.

In the Freeze interface, waveforms of different pages can be by tapping **[PgUp]/[PgDn]** and step can be adjusted by the user.

In the Freeze interface, tap **[Print]** to print the waveforms.

Tap **[Report]**, and then choose the type of the report, you can print the selected report.

In the Freeze mode, split-screen display of lead waveforms is same as that in the main interface; please refer to

Split-screen display for details.

Chapter 5 Setting System Parameters

In the Main interface, tap **[Menu]** to enter the configuration menu.

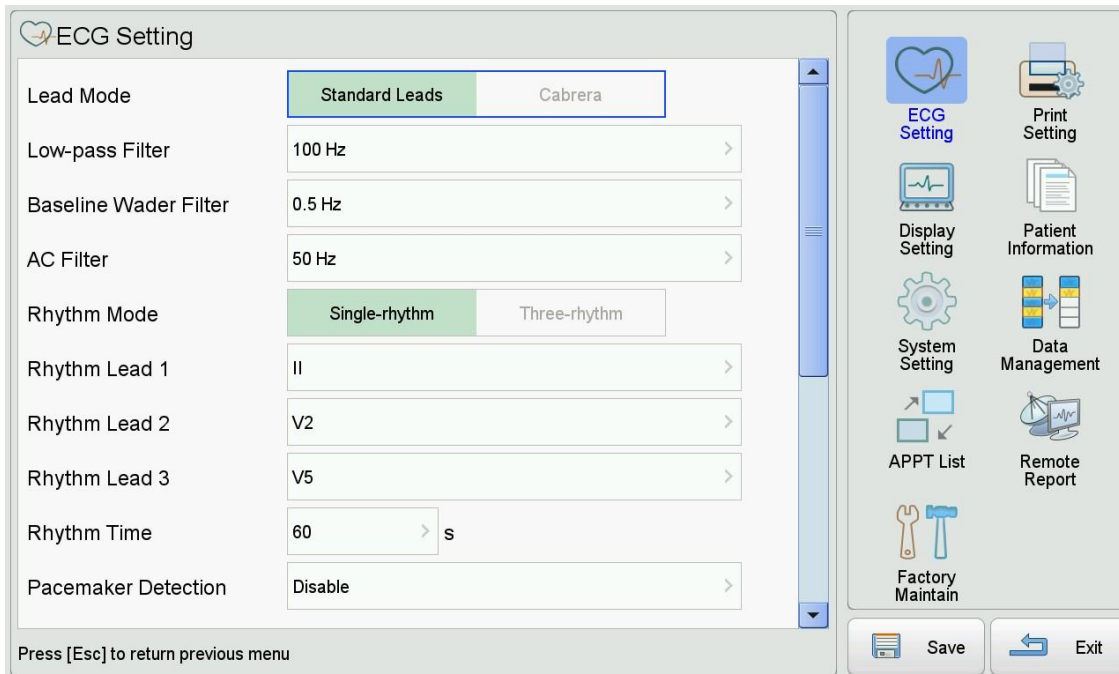

Figure 5- 1 Configuration Menu

EXPLANATION

Tap **[Save]** before exiting to avoid loss of setting because of sudden power lost.

1 ECG Setting

Enter **[ECG Setting]** to set parameters about Electrocardiograph. See following table:

Name	Value	Default	Description
Lead Mode	Standard Leads, Cabrera	Standard Leads	Select one option for lead mode.
Low-pass Filter	25 Hz, 35 Hz, 75 Hz, 100Hz, 150 Hz, 250 Hz	100 Hz	Select one option for low-pass filter, baseline wander filter and AC filter. The default value varies from different ECG types.
Baseline Wander Filter	0.01 Hz, 0.02 Hz, 0.05 Hz, 0.35 Hz, 0.5 Hz, 0.8 Hz	0.5 Hz	

Name	Value	Default	Description
AC Filter	OFF, 50 Hz, 60 Hz	50 Hz	
Rhythm Mode	Single-rhythm, Three-rhythm	Single-rhythm	Select one option for Rhythm mode.
Rhythm Lead 1	I, II, III, aVR, aVL, aVF, V1, V2, V3, V4, V5, V6	II	Select lead as Rhythm lead.
Rhythm Lead 2	I, II, III, aVR, aVL, aVF, V1, V2, V3, V4, V5, V6	V2	
Rhythm Lead 3	I, II, III, aVR, aVL, aVF, V1, V2, V3, V4, V5, V6	V5	
Rhythm Time	30 s~300 s	60 s	Select one option for rhythm recording time.
Pacemaker Detection	Disable, Weak, Normal, Enhance	Disable	Set the pacemaker detection sensitivity according to patient's pacemaker
Arrhythmia Mode	Disable, Enable	Disable	Set the arrhythmia detection mode.
Wave Sample Time	10 s~24 s	10s	Select one option for waveform sampling time.
Pre-acquisition Time	0~10s	8s	Select the pre-acquisition time.
Pre-acquisition	Disable, Enable	Disable	Set the pre-acquisition mode. If it is enabled, it can print out pervious waveforms.
Auto-save	Disable, Enable	Enable	Set whether to automatically save the report.
Data Format	ECG, XML, JPEG, DICOM, PDF	ECG	Select one option for data format.
Auto Upload	Disable, Enable	Disable	Set whether to automatically upload the waveforms and report after printing.

QTC Formula	Bazett, Fridercia, Framingham, Hodges	Bazett	Select one option for QTC formula.
--------------------	--	--------	------------------------------------

Name	Value	Default	Description
Examination Type	Normal, Physical Examination	Normal	Select one option for examination type.

 **CAUTION**

In sequence to prevent the pacemaker from being detected repeatedly or omitted, you should set the detection sensitivity according to the actual clinical need.

 **EXPLANATION**

When using the ECG machine for physical examination of large number of people, it is recommended to select

[Physical Examination] for [Examination Type].

Print Setting

Enter [**Printer Setting**] to set parameters about printer. See following table:

Name	Value	Default	Description
Gray Level	1~8	6	Select one option for gray level.
Baseline Width	1~4	2	Select one option for waveforms thickness.
Print Speed	5 mm/s, 6.25 mm/s, 10 mm/s, 12.5 mm/s, 25 mm/s, 50 mm/s	25 mm/s	Select one option for paper speed.
Report Format	Simple Report, Detail Report, Median Beat Report, Manual Report, Disable	Simple Report	Select one option for report format.
File Print Format	/	Current Page	Select one print format for report analysis interface.
Analysis Output	Disable, Enable	Enable	Select whether to print the a resting ECG analysis automatically.

Name	Value	Default	Description
Diagnostic Conclusion	Disable, Enable	Enable	Select whether to print the diagnostic conclusion in the analysis result (this function is only available when analysis output is on).
Print Grid	Disable, Enable	Disable	Select whether to print the grid on the paper.
PDF Grid	Disable, Enable	Enable	Select whether to display and print the grid on the PDF report.
Printer	Disable, Built-in Thermal Printer	Built-in Thermal Printer	Select whether to print using built-in printer.
Record Mode	Refer to the appendix Technical Specification and the equipment your purchased.	Auto	Select one option for report mode.
Record Format	Refer to the appendix Technical Specification and the equipment your purchased.	12x1	Select one option for report mode.
Auto Print	Disable, Enable	Disable	Select to print the report automatically or manually.
Print Data Type	Real Time, Synchronous	Real Time	Select one option for print data type.
Automatic Position	Disable, Enable	Enable	If enabled, the system will allocate the print area according to the real height of each waveform to reduce waveform overlap; if disabled, the system will equally allocate the print area for each waveform.
Cycle Time	1~60min	60 min	Select one option for cycle time and cycle
Cycle Interval	1~ Cycle Time that customized	1 min	interval for cycle recording mode.

Display Setting

Enter **[Display Setting]** to set parameters about display. See following table:

Name	Value	Default	Description
Display Style	Classic White, Classic Black	Classic White	Set the display style of the screen.
Background Grid	Disable, Enable	Enable	Set the Background grid Disable or Enable.
Display Format	Same Screen, Split-screen	Same Screen	Set the waveforms to display in the same time (same screen) or different time (different screen).
Lead Format	Refer to <i>Technical Specification.</i>	3x4	Select one option for lead format.
Lead Standard	IEC Standard, AHA Standard	IEC Standard	Select a lead standard to display.

Patient Information

Enter **[Patient Information]** to set patient information. See following content:

Sub-ID No., Gender, Age, Date of birth, Height, Weight, BP, Race, Pacemaker, Medication, Accession No., Ref-physician, Technician, Physician, Ref-department., Room No., Urgent, Hospital No., User Defined.

EXPLANATION

Age and Date of Birth cannot be selected at the same time.

System Setting

Enter **[System Setting]** to set system parameters. See following table:

Name	Value	Default	Description
Demo Mode	Normal ECG, Arrhythmia ECG, Disable	Disable	Select a waveform type displayed in the main interface as a demo. Arrhythmia ECG is selected for demonstrating auto trigger mode.
System Language	English, etc.	To be determined by the shipping country	Set the system language.
System Version	Version No., Compile Time, Acquisition Module Version	/	Display the details of software version.
System Time	Current Time, Date	/	Display the details of time and date and
Network Setting	Format Date Time Cable Network, WIFI,	Cable Network	to set the date format. Select one option for network setting.
Transfer Protocol	TCP, FTP	TCP	Select one option for transfer protocol.
Cable Network	IP Address, Subnet Mask, Default Gateway	/	Set the value of IP address, subnet mask, and default gateway.
WIFI Network (Optional)	SSID, password and Security DHCP: Disable, Enable IP address, subnet mask and gateway		Set the value of SSID, password and Security. Set DHCP to enable or disable accordingly. If DHCP is disabled, set the value of IP address, subnet mask and gateway.
3G Network	IP Address, Subnet Mask, Default Gateway	/	Set the value of IP address, subnet mask, and default gateway.
Server Setting	IP Address, Port	/	Input the value of IP Address, Port of server.

FTP Server	User, Password, Path /	Input the value of user, Password and
-------------------	------------------------	---------------------------------------

Name	Value	Default	Description
			path of the FTP server.
Silent Mode	Disable, Enable	Disable	Set the silent mode Disable or Enable. If silent mode is enabled, all sound, including alarm tone and key tone will be off.
QRS Tone	0~10	6	Select one option for three sound tones. If all three options are zero, a silence icon will be displayed in the main interface.
Alarm Tone			
Key Tone			
Default Memory	Internal Memory, USB Flash Drive, SD card	Internal Memory	Select the default memory to storing files.
Memory Format	Internal Memory Formatting, SD Card Formatting	Internal Memory Formatting	Format the specified memory. The files can not be recovered after formatting.
Standby Time	None, 5 min, 10 min, 30 min, 1 h, 2 h	Disabled	Set the standby time.
Auto Power-Off	None, 30 min, 1 h, 2 h, 3 h	Disabled	Set the auto power off time.
System Password	Disable, Enable	Disable	Set the system password disable or enable.
Password Setting	0~9999	1234	Set the value of password when the system password is enabled.

General Setting	1~10	1	Select one option, and then set up according to your habit, all your setup will be stored in this option to facilitate your next use. Different doctor or different check up can occupy different options.
------------------------	------	---	--

Name	Value	Default	Description
Import Setting	Import from USB flash disk, Import from SD Card	/	Import files from the specified memory.
Export Setting	Export from USB flash disk, Export from SD Card	/	Export files to the specified memory.
Touch Screen Cal.	/	/	Make calibration to the touch screen.
Factory Default	/	/	Restore to factory default.
Hospital	/	/	Input the name of hospital.
Device No.	/	/	Input the number of this ECG machine.

CAUTION

Demo mode is designed for presentation only. Do not use this mode in clinical analysis, for demo waveforms may be mistaken as that of patient and misdiagnose may happen.

Remote Report

Tap **[Remote Report]** to enter Remote Report menu. Tap **[Setting]** to input the **[Start Time]** and **[End Time]**, and then tap **[Load]**, the ECG files of that duration can be downloaded into the ECG machine and displayed on the interface below:

Indication Area

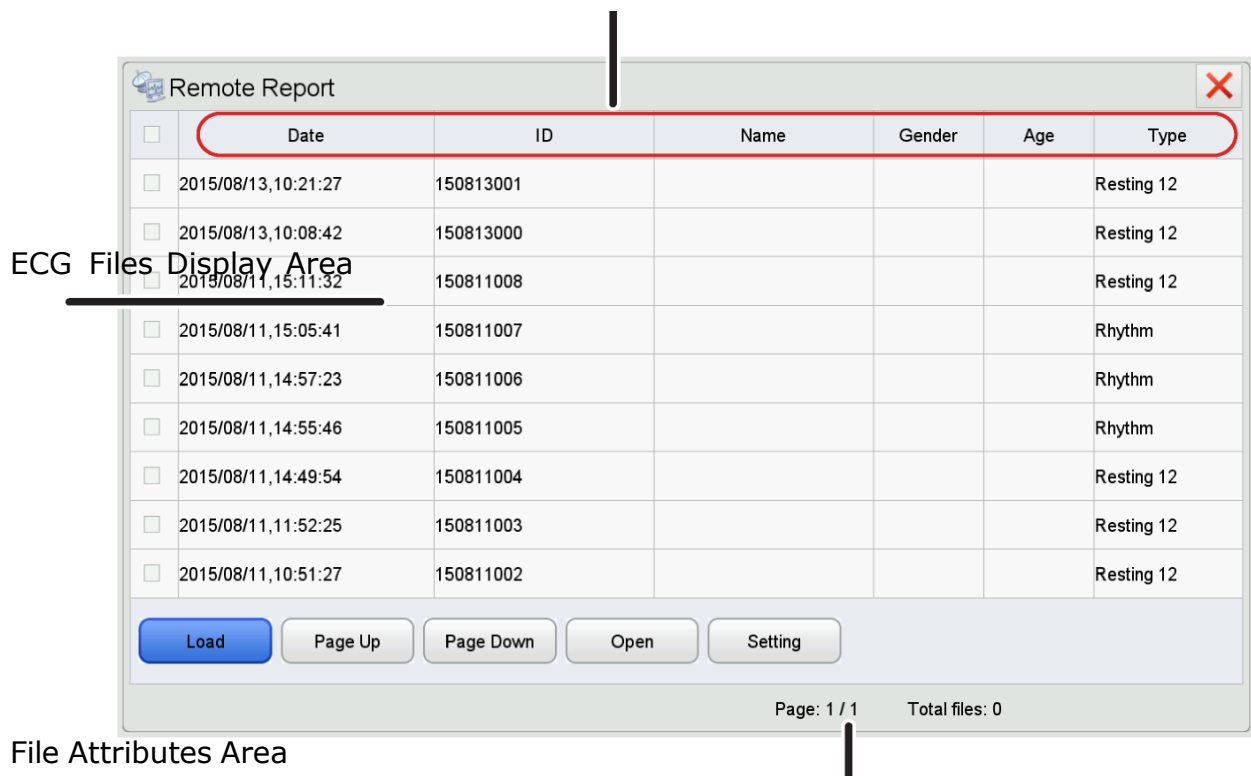

File Attributes Area

Figure 5- 2 Remote Report

In the above interface, you can tap **[Page Up]/[Page Down]** to turn to previous/next page; tap **[Open]** to review the selected files.

Factory Maintain

Only the authorized service engineer can set up **[Factory Maintain]**, please contact with our customer service if necessary.

-- *Blank page* --

Chapter 6 Data Management

Tap **[Menu] > [Data Management]** to enter the Data Management interface. Select one source of storage medium from Local (ECG machine itself), USB 0, USB 1 or SD card, the ECG files will be uploaded.

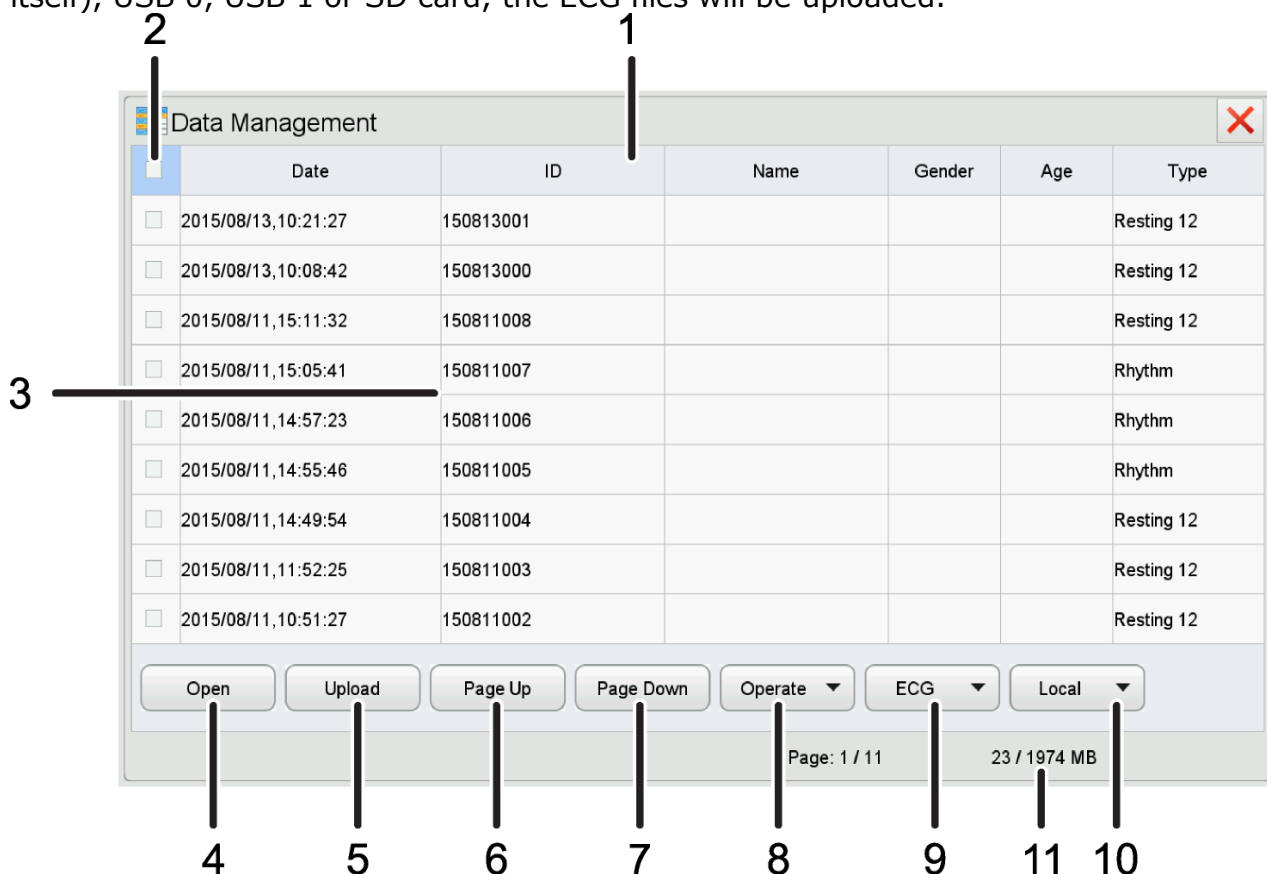

Figure 6- 1 Data Management

Number	Name	Description
1	File Attributes Area	Selecting any file attribute, and sorting files by tapping the tab.
2	Select All	Check to select all the ECG files in the current page.
3	ECG Files Display Area	Display basic patient information of all the ECG files.
4	Open	Open one patient's ECG file.
5	Upload	Upload selected ECG files to ECG management system or server.
6 and 7	PageUp/PageDown	Browse ECG files in previous or next page.
8	Operate	Select all , Refresh , Copy , Move , Delete , and Search the ECG files. Search ECG files according to ID number, name, age, time and

Number	Name	Description
		symptom.
9	ECG File Type	Select one option for ECG file's format, including ECG, XML, JPEG, DICOM and PDF.
10	Select Storage Medium	Select one option for the storage medium, including local, USB 0, USB 1, and SD card.
11	Indication Area	Indicate pages of ECG files and internal memory.

1 Open an ECG File



Check an ECG file, and then tap **[Open]** or press right or left button in to open the file.

EXPLANATION

When you select more than one file to open, the default file is the first selected file.

2 Edit an ECG File

After opening the ECG file, you can edit the patient information and analysis result, and also upload, save and print the file. You can refer to **Analysis Report Mode** to get the content and function of the ECG file.

Delete ECG Files



Tap or press to select the desired file and tap **[Operation]** > **[Delete]**.

CAUTION

Deleted files cannot be recovered. Please use this option cautiously.

Copy and Move ECG Files

Select one or more ECG files, operate as following to transfer the ECG files.

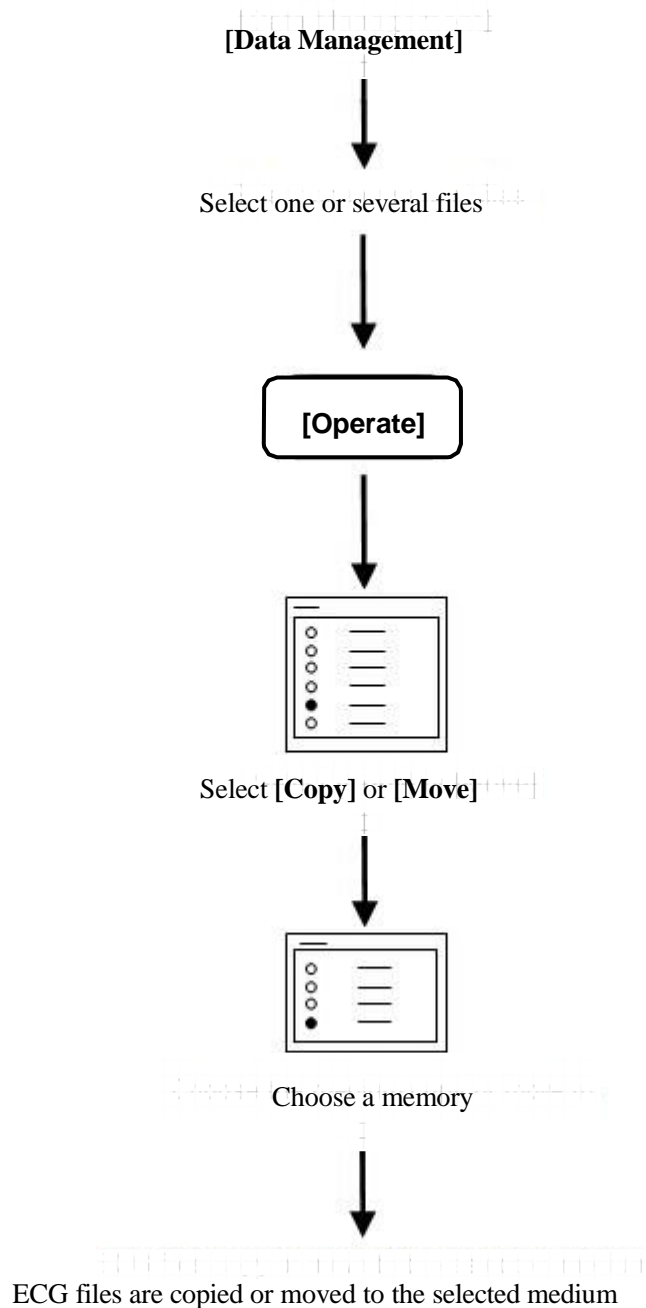

EXPLANATION

Files can be copied or moved between the local ECG machine and external storage medium. ECG files on the local machine will be deleted if the user moves them.

After selecting files and a path, the files will be copied to the selected path. When copy files to SD card and

USB disk, the system will create a new directory in the SD card and USB disk to store the selected files, for example "ecg database", etc.

When there is not enough memory, the system will indicate that. You should select new memory to make files copying or moving successfully.

Please regularly clear data in a storage medium or the speed of the machine will be slowed down.

 **CAUTION**

When copying or moving the files, the continuity of power supply must be assured, or the files may be missing.

When copying or moving the files, it is not allowed to insert or unplug the USB disk or SD card; otherwise, it may cause abnormality of the ECG machine.

Chapter 7 Maintenance

Main Unit

 **CAUTION**

Gently disconnect the patient cable and power cable without forcibly pulling the lead wires.

Clean the ECG machine as well as the accessories and cover the unit from dust.

Store the unit in a dry and cool environment and avoid excessive shocking and vibration.

While cleaning the unit, neutral cleanser is recommended. Do not immerse the unit in the liquid.

Patient Cable

 **CAUTION**

The lead wires must be periodically checked for good connection. Damage may cause abnormal ECG waveform at some or all leads.

The user should avoid twisting the patient cable, or the life time will be shortened.

Cleaning and Disinfection

Before cleaning, power off the ECG machine and disconnect it from the AC power. Do cleaning first before disinfection.

The process to clean and disinfect the ECG machine, cables, lead wires and reusable electrodes are as follows:

Use a clean soft cloth absorbing an amount of cleanser or disinfectant to wipe the surface carefully and avoid touching connectors of the ECG machine and accessories.

When necessary, wipe the superfluous cleanser or disinfectant with dry cloth.

Place in the ventilated and cool environment to dry the ECG machine and accessories.

Sterilization operation for this ECG machine and accessories is not recommended, unless the manual of the

accessories has requirement.

 **CAUTION**

While cleaning and disinfection, do not splash liquid into the ECG machine and the accessories.

Disinfections may cause damage to the ECG machine or accessories to a certain degree. It is suggested that only when necessary, disinfect the ECG machine and accessories.

Neutral cleanser or disinfectant is recommended.

Recording Paper

 **CAUTION**

To ensure good ECG recording, please use suitable thermal recording paper for the ECG machine. Incorrect recording paper can damage printer head and cause problem such as blurring trace and incorrect paper running. Pay attention to the following comments on recording paper.

Never use recording paper coated with wax for the ECG machine. It may cause serious problems to the printer head.

When exposed to high temperature, high humidity and direct sunlight, the recording paper will deteriorate. It is therefore required to store the thermal recording paper in a dry and cool environment.

When exposed to fluorescent light for a long time, the recording paper will deteriorate.

When stored with polyvinyl chloride (PVC), the recording paper will deteriorate.

If the thermal recording paper is stored overlapping for a long time the printing impression which will leave traces in other pages, which will cause mislead readings.

Use suitable size recording paper for the ECG machine. Or, it may cause damage to the printer head and Silicon rubber shaft.

Battery

The ECG machine is equipped with a built-in rechargeable battery to assure continuous operation when AC power is unavailable. Charging, capacity indication and replacement of the battery are described below:

Charging

The ECG machine is designed with a charger and protector for the battery.

Please turn off the machine first before charging the battery.

The battery-charging indicator on the operation keyboard will become green when the battery is charged completely.

If the ECG machine is to be stored or without use for a long time, discharge and charge the battery at least once every three months (discharge the battery until the machine turns off automatically, and then fully charge the battery).

Capacity indication

When the unit is powered by battery, there will be a symbol of battery capacity indication displayed on the LCD.

For example:



Full battery capacity, it can work continuously for about 3 hours.



Battery capacity is sufficient.



Insufficient battery capacity, charging is required.



Battery capacity is going to running out, immediate charging is demanded.



Battery capacity has already run out and blackout may happen at once, immediate charging is demanded.

Battery replacement

The battery should be replaced by the professionals according to the following procedures.

Power off the ECG machine and disconnect the AC power cable.

Flip over the ECG machine and disassemble the battery back cover based on the instruction on the back cover.

Disconnect the battery plug and take out the battery.

Replace the existing battery with a new one. Pay attention to polarity and connection.

Install the back cover.

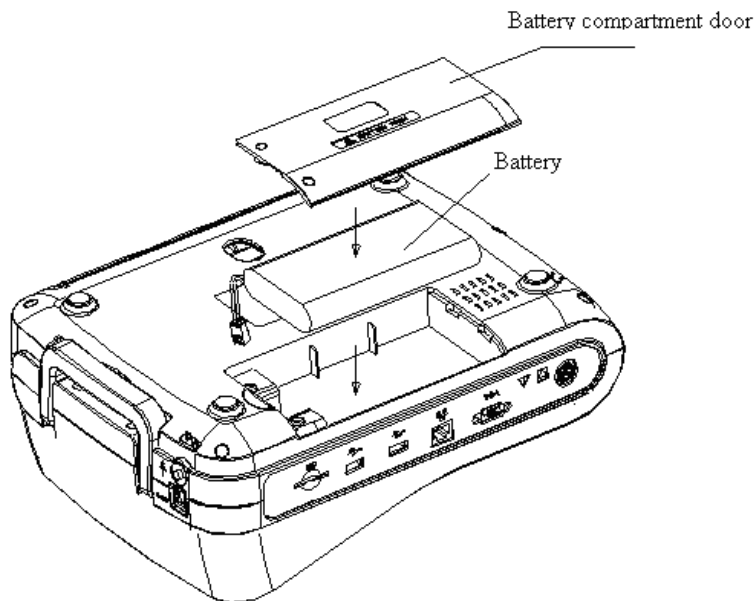

Figure 7- 1 Battery Replacement

EXPLANATION

Refer to **Foreword** for other warning information of battery.

Silicon Rubber Shaft for Printing

The silicon rubber shaft shall be kept clean, smooth and free from dirt. Otherwise, the ECG machine may print out unsatisfied ECG trace. To clean dirt from the shaft, wipe the shaft with soft cotton moistened with medical alcohol and at the same time rotate shaft until it is clear enough.

Thermal Printing Head

Residue and dirt on the thermal printer head could affect the clarity of recorded ECG waveform. To clean the thermal printer head, open the paper cover and clean the printer head with soft cotton moistened with medial alcohol. It is not permitted to clean the printer head with a sharp object, which can cause permanent damage to the printer head. Thermal printer head maintenance should be done at least once a month.

Chapter 8 Troubleshooting

1 Lead Fault

Data saturation or overflow happens. Solution:

Ensure that all leads are in good contact, and wait for half minute or the waveforms on the screen are stable, and then start printing.

Straight line is printed in some leads. Solution:

Check if the metal piece of limb electrode contacts with the body properly; if not, adjust the position of the limb electrode, and adjust the tightness if necessary.

Check if the limb electrodes and chest electrodes are oxidized or faded, and clean the accessories or replace with new ones. Oxidation and aging cause conductive deterioration of the electrodes, resulting in poor signal transmission.

Treat the skin of the patient with alcohol; because dry skin causes skin resistance to become larger, which will impact the signal collecting.

Please clean the joints of lead wires, suction ball and limb clip, reinstall and tighten all joints. After long-term use, the joints will have dirt or become loose, resulting in poor signal transmission.

Check if the appearance of the lead wires has obvious fracture; if yes, replace with new lead wire. If not, connect a proper lead wire to the device. If the waveforms are stable, the lead wires have problem and have to be replaced.

If there is no lead wires available, check if the lead wires conduct with a multimeter. First check if the inner conductors of the lead wires are conductive. Generally speaking, the acceptable resistance shall be about 10 k Ω . Then check if there is a short circuit between the outer shield and inner conductor. The resistance shall be infinity. If the lead wires have a problem, please contact our customer service to replace new lead wires.

The other reason for lead fault can be caused by failure in signal communication. Please exclude other causes for lead fault problems first, and then contact customer service if necessary.

Printer Failure

Unclear printing. Solution:

Whenever a printer fault occurs, such as poor or incorrect ECG recording, you may try to clean the thermal printer head with soft cotton dipped with medical alcohol.

If the quality of the thermal paper is poor or the paper is not used for a long time, which may result in reduced performance of thermal layers. Please replace with provided or specified recording paper.

If the above methods are not applicable, guide the user to test the print head and check if the print head has breaking point; if yes, contact the customer service to replace the thermal print head.

Upper half or lower half is blank. Solution:

Check if the bearing on both ends of the rubber shaft of the paper compartment cover is worn, and replace with new bearing if yes.

All paper or most part is blank. Solution:

Make sure that the thermal recording paper is not installed backwards.

Check if the print head is stuck by dirt (such as adhesive tape); this often occurs when new print paper is replaced.

3 Keyboard Failure

If key failure happens, the professional maintenance staff can locate the failure by "Key Test" in **[Factory Maintain]**.

Keyboard failure is probably caused by loose connection between the keyboard panel and the System Control Board due to shocking or vibration during transportation. If necessary, a professional service engineer will disassemble the ECG machine and reconnect the inner cable. At the same time, check keyboard, if key may be stuck for aging.

Indication of Lead Off

This ECG machine can detect the lead connecting status continuously. When the leads are not well connected to the main unit, it means that the signals can not be transferred correctly, thus there is "lead off:*" indication, accompanied by voice alarm. The symbol "*" represents the fault lead, the waveform of which will display as a straight line. Please check carefully whether the connection among the related electrodes, human body, patient cable and the main unit remains well.

AC Interference

Apparent and regular trembling of ECG waveform in the process of recording due to AC interference is shown as below.



Causes of baseline wander are varied, please do following checks one by one:

Make sure the ECG machine is properly grounded according to the instructions.

Make sure the patient cable and electrodes are properly connected.

Make sure the electrodes and the patient skin have been covered with ECG gel.

Make sure the exam bed is properly grounded.

Make sure the patient is not in touch with the wall or the metal part of the bed.

Make sure the patient is not in touch with anybody else.

There shall be no large power electric equipment (such as X ray machine, ultrasound scanner and etc.) operating nearby.

The patient shall not be wearing some jewelry like diamond.

CAUTION

Set AC filter to ON if AC interference still exists after the above checks are completed.

6 EMG Interference

Irregular trembling of ECG waveforms due to EMG interference is shown as below.



Causes of baseline wander are varied, please do following checks one by one:

Make sure that the exam room is comfortable for examination.

Soothe the patient from irritation or excitement.

Make sure the exam bed is in suitable size.

Never have talks with the patient during ECG recording.

Make sure the limb electrode is too tight to make the patient uncomfortable.

CAUTION

Set EMG filter to lower value if EMG interference still exists after the above checks are completed, and keep in mind that the recorded ECG waveforms, particularly R wave, will be somewhat attenuated.

Baseline Wander

Irregular movement of ECG baseline due to baseline drift is shown as below:

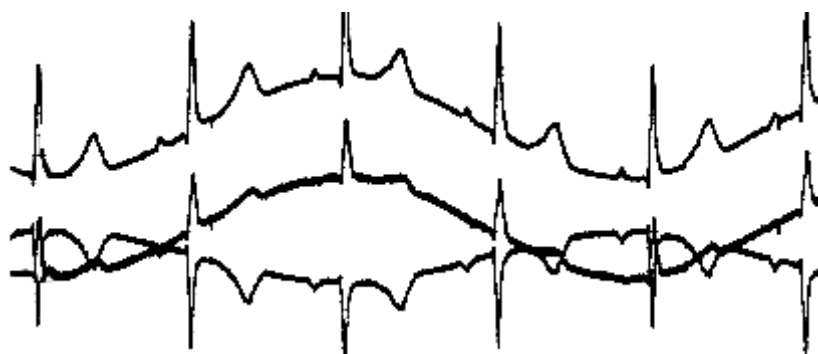

Causes of baseline wander are varied, please do following checks one by one:

Make sure the electrodes are in good contact with skin.

Make sure the connection between the patient cable and electrodes.

Make sure the electrodes are clean and patient skin contacted with the electrodes has been well pretreated.

Make sure the electrodes and skin are covered with ECG gel.

Keep the patient silent and motionless, and keep the patient from hyperventilation.

Used electrodes shall not be utilized with new ones in patient examination.

 **CAUTION**

If the problem still can't be cleared, please turn up the baseline wander filter, keep in mind that the recorded ECG waveforms, particularly T wave and ST segment, will be somewhat distorted.

The ECG machine can not be turned on

AC power is not working properly and the battery is exhausted. Solution: First check if the power outlet connects properly, if the power line and the machine connect properly, then check if local AC voltage is good. If everything is ok, check if the fuse is proper. If everything is normal after above examination, return the machine to the manufacturer for repair, for it may be damaged. After turning on, the machine turns off automatically after a few minutes.

Solution:

While working, if the screen displays the battery power, the machine is using the battery, but the battery power is insufficient, resulting in automatic shutdown. Please supply the machine with AC power, or charge the battery before working. If the user is using AC power and the machine still turns off automatically, please check according to step1.

Paper Feeding Failure

Press , but paper is not fed. Solution: Check if the keyboard has been damaged and replace damaged keyboard.

Press , the paper is not fed, and there is abnormal sound from recorder.

Solution:

First check if the recording paper is installed properly, and if the gear on the cover of paper magazine is in

good condition.

Paper feeding isn't smooth, paper is stuck, or waveforms are compressed.

Solution:

First check if the thermal paper complies with the standard, then if the paper is installed properly, or replace a new roll of paper. Finally, replace the paper shaft.

attery is quickly charged and discharged

If the battery is often not fully charged, the performance will be deteriorated.

Solution:

It is recommended to charge the battery continuously until the battery is fully charged and activated for the first two times. Supply the machine with AC power as far as possible.

Wrong Analysis Result

For the case for some special populations (such as pregnant women, the user of vascular drugs, etc.) or mixed by obvious interference in the recording process, the analysis result of the resting ECG analysis of this ECG machine may be inaccurate. The possible reason may be as followings:

Poor contact between electrode and patient skin, caused by improper skin treatment and incorrect connection.

The patient has relatively large movement in the recording process.

Gender or age isn't entered;

If there is too much AC, EMG and breathing interference, the identification of P wave and Q wave is not reliable sometimes; if there is baseline wandering, the identification of ST segment and T wave is not reliable sometimes.

If QRS complex has low voltage, R-wave may be missed, and the electrical axis measurement and the identification of QRS dividing point can be unreliable. Or frequent ventricular contraction occurs or a variety of arrhythmias merge, the relevant detection parameters may be unreliable.

The filter settings are incorrect. Solution:

Treat as **Apply Electrode** and wait until the waveformws are stable before reanalyzing.

Enter the patient gender and age correctly.

Exclude the interference as the methods described in **AC Interference**, **EMG Interference** and **Baseline Wander** before reanalyzing.
Reset to an appropriate filtering value.

File Uploading Failed

The most possible reason is that network settings have problems, please check the network connection and refer to

Network Connection to re-set the network.

-- *Blank page* --

Appendix A Package and Accessories

Packing List

S/No	Item Name	Qty
1	QRS 12 ECG Machine	1 unit
2	Patient Cable	1 set
3	Chest Electrode	6 pieces
4	Limb Electrode	4 pieces
5	Power Adaper	1 piece
6	Power Cable	1 piece
7	Equipotential Cable	1 piece
8	Z-fold Thermal Recording Paper	1 piece
9	User Manual	1 copy

Dimensions and Weight

Length × Width × Height	345 mm×260 mm×128.5 mm
Net Weight	About 3.4 kg

 **CAUTION**

Please open the package according to instructions on the packing box.

Accompanying accessories and documents shall be checked according to the packing list before starting checking on the unit.

Whenever there will be mismatch of the accompanying materials with the packing list, contact our customer service immediately.

To ensure good performance and safe operation of the ECG machine, please use the accessories supplied by the manufacturer.

The package box should be kept well for the regular inspection or maintenance for the machine.

Appendix B Technical Specification

1 Specifications

Main Unit

Lead	Standard 12-lead
Acquisition Mode	Simultaneous 12-lead
Record Format	3×4, 3×4+1R, 3×4+3R, 6×2, 6×2+1R, 6×2+3R, 12×1, 12×1+1R
Record Mode	Economic, Auto, Manual, Upload, Cycle, Trigger
Lead Format	3×4, 3×4+1R, 6×2, 6×2+1R, 12×1
Long-term Recording	Record for a long term (30 s~300 s) and rhythm analysis
Measurement Parameters	HR, PR interval, QRS interval, QT/QTC interval, P/QRS/T axis, RV5/SV1 voltage and RV5+SV1 voltage
Filters	AC, low-pass and high-pass filters
CMRR	>89 dB >100 dB (with AC interference filter)
Input CIR current	≤0.1 μA
Patient Leak Current	<10 μA
Time Constant	≥3.2 s
Frequency Response	0.05 Hz~250 Hz
Noise Level	≤15 μV _{p-p}
Sensitivity Threshold:	≤20 μV
Signal Gain	Eight levels as 1.25 mm/mV, 2.5 mm/mV, 5 mm/mV, 10 mm/mV, 20 mm/mV, 10/5 mm/mV, 20/10 mm/mV, Auto Gain (Auto Gain is just for the Automatic mode)
Calibration Voltage	1 mV±5 %
Accuracy of Input Signal	Using the method described in 4.2.7.1 of AAMI EC11 to test the overall system

Reproduction	error, which is within $\pm 5\%$; Using method A and D described in 4.2.7.1 of AAMI EC11 to test frequency response. Because of sampling characteristics and the asynchronism between sample rate and signal rate of the ECG machine, digital systems may produce a noticeable modulating effect from one cycle to the next, particularly in pediatric recordings. This phenomenon, which is not physiologic, shall be clearly described in the operator's and service manuals.
Input Circuit:	Floating circuit input
Input Impedance	$\geq 2.5\text{M}\Omega$ (full-band)
Sampling Rate of Signals	8000 Hz

Recorder Specification

Recorder	Thermal Dot Matrix Word Printing System 8 points/mm (perpendicular) 40 points/mm (horizontal, 25 mm/s)
Recording Paper	210 mm×150 mm Z-fold paper
Paper Speed	(5, 6.25, 10, 12.5, 25, 50) mm/s, $\pm 5\%$

Other Specification

Patient Cable	Standard 12-lead cable with defibrillation-proof
Display on LCD	1280×768, 8.9-inch LCD touch screen, the whole instrument work status, time, heart rate, and with the backlight
Safety Classification	IEC60601-1 Class I Type CF
AC Power Supply	100 V~240 V, 50 Hz /60 Hz, 110 VA

DC Power Supply	Rechargeable lithium battery, 14.8 V/ 4400mAh. In environment temperature ranging from 20 °C to 30 °C and with the machine turning off, the charging time is not more than 4 hours to charge the
------------------------	---

	battery to 90%.
	In environment temperature ranging from 20 °C to 30 °C, the continuous working time is not less than 3 hours while the ECG device is continuously printing.

2 Environment Requirements

1	Transportation
	Environment Temperature -20 °C~+55 °C
	Relative Humidity ≤95 % (No condensation)
	Air Pressure 70 kPa~106 kPa
	Transportation: avoid direct sunshine and rain.
2	Storage
	Environment Temperature -20 °C~+55 °C
	Relative Humidity ≤95 % (No condensation)
	Air Pressure 70 kPa~106 kPa
	The packed ECG should be stored in the well-ventilated room without corrosive gases.
3	Using
	Environment temperature +5 °C~+40 °C
	Relative humidity ≤95 % (No condensation)
	Air pressure 70 kPa~106 kPa

-- *Blank Page* --

-

Appendix C Working Principle and Block Diagram

Power Supply Subsystem

Working principle:

By ways of AC to DC high frequency power switching technique, the switching power supply output 20V DC voltage. This voltage works to charge the built-in rechargeable battery at constant voltage and limited current, and at the same time, applies to the power switchover circuitry together with the battery output. If the switchover circuitry is turned on, several stable power outputs will be generated through various switching power technique, including main power supply of +5V and +24 V (+12 V) by the switching power stabilizer, +3.3 V, +1.8 V and -5 V by the power supply transformation.

+5V, +3.3 V, +1.8 V and -5 V supply power for the control system circuitry with the equipotential as reference with 750mA normal load, 3A output current capacity and 3.75A output current limit for short circuit protection.

The +24 V (+12 V) voltage supplies power for the paper driving motor and the thermal printer. The motor is driven by means of width modulation and wave chopping technique in sequence to improve power efficiency. It has about 500mA as normal load, 850mA as output current capacity and 1.2A output current limit for short circuit protection. The self-excitation power switching circuitry transforms the output of the switchover circuitry to several voltages for analog circuitry. The +5V voltage needed by isolated digital circuitry is the direct stabilized output of the switching power supply, of which the normal load is about 150mA and the current capacity is 300mA. The +8V and -8V voltage for the isolated analog circuitry is the un-stabilized output from the switching power supply. Its normal load is about 60mA and has 100mA current capacity.

Block diagram (Schematics and parts of list of this unit are only provided for qualified service center under supervision of the manufacturer.)

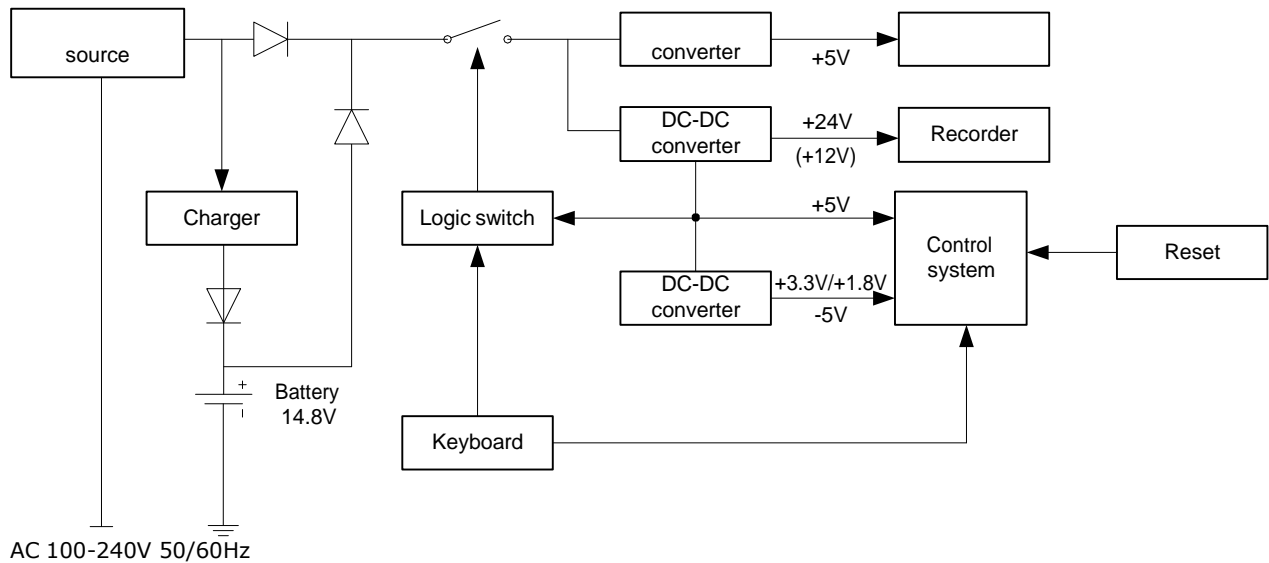

Acquisition Module

Working principle

By connecting to the control system of the ECG machine, the acquisition module gets its power supply and communication function. When connecting, the analog circuit and control circuit of acquisition module are powered through the isolated DC/DC switching output. The analog circuit is composed of input protection circuit, anti-aliasing low-pass filter and ECG analog front chips. The electrodes acquire the millivolt electrical signals from human body, which will be converted to digital signals by ECG analog front chips first, then transferred to the processor that controls the converter in the ECG analog circuit, ECG data processing and operation keys on acquisition module. The sampling rate of signals is 8000Hz with 250Hz as bandwidth (-3dB), which meets the standard of AHA and CSE (sampling rate no less than 500Hz). After the signals are processed and filtered, they are sent back to the control system of the ECG machine through optically coupled isolation interface.

Block diagram:

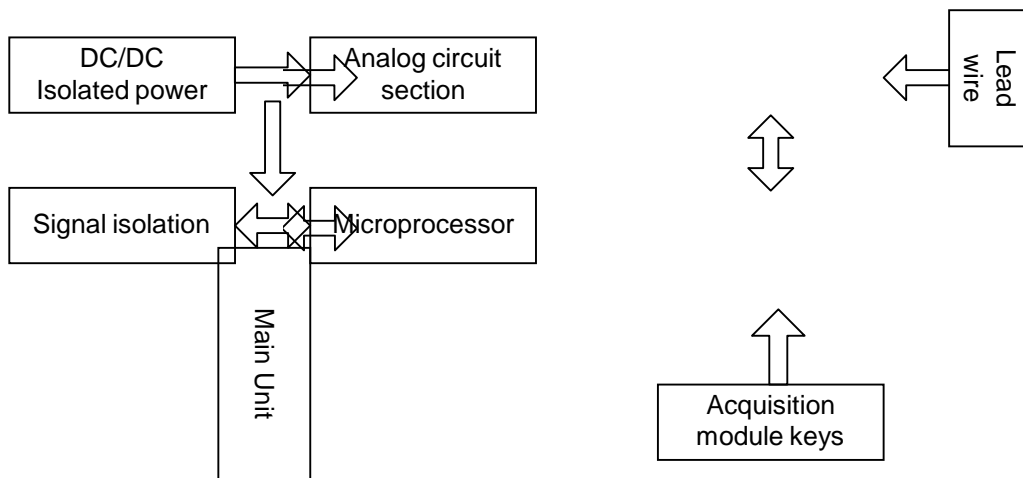

Leads of acquisition module:

Lead nomenclature	Definition	Name of lead
I II III	$I=L-R$ $II=F-R$ $III=F-L$	Biopolar limb leads (Einthoven)
aVR aVL aVF	$aVR=R- (L+F)/2$ $aVL=L- (R+F)/2$ $aVF=F- (L+R)/2$	Augmented leads (Goldberger)
V1 V2 V3 V4 V5 V6	$V1=C1- (L+R+F)/3$ $V2=C2- (L+R+F)/3$ $V3=C3- (L+R+F)/3$ $V4=C4- (L+R+F)/3$ $V5=C5- (L+R+F)/3$ $V6=C6- (L+R+F)/3$	Unpolar chest leads (Wilson)

Control System

Working principle

The control system consists of controllers for printer, keyboard, LCD screen and a CPU subsystem. Through high-speed photo-couplers, CPU subsystem receives lead signals from the Data acquisition Subsystem and applies them

to the printer controller after digital filtration, gain adjustment and printer

driving, then completes the ECG waveforms printing. The lead data will also be measured and interpreted by CPU. In addition to measurement and interpretation on the printed ECG waveform, CPU also receives interruption signals and key codes from the keyboard controller to carry out key interrupt routine. Acquisition and processing of signals for detection of leadoff, out-of-paper detection, battery capacity management, automatic power off, CRO output and EXT input are all managed by CPU. The printer controller receives instructions and data from the CPU, and works to manage the buffering area and generate control signals for the stepping motor and thermal print head to print out ECG waveforms and related information. The keyboard controller works to generate keyboard scan signals, removes key bounces when key is pressed, and sends key codes and interruption signals to CPU for further processing. LCD controller receives instructions and data from CPU, and works to display the unit's operation status.

Block diagram

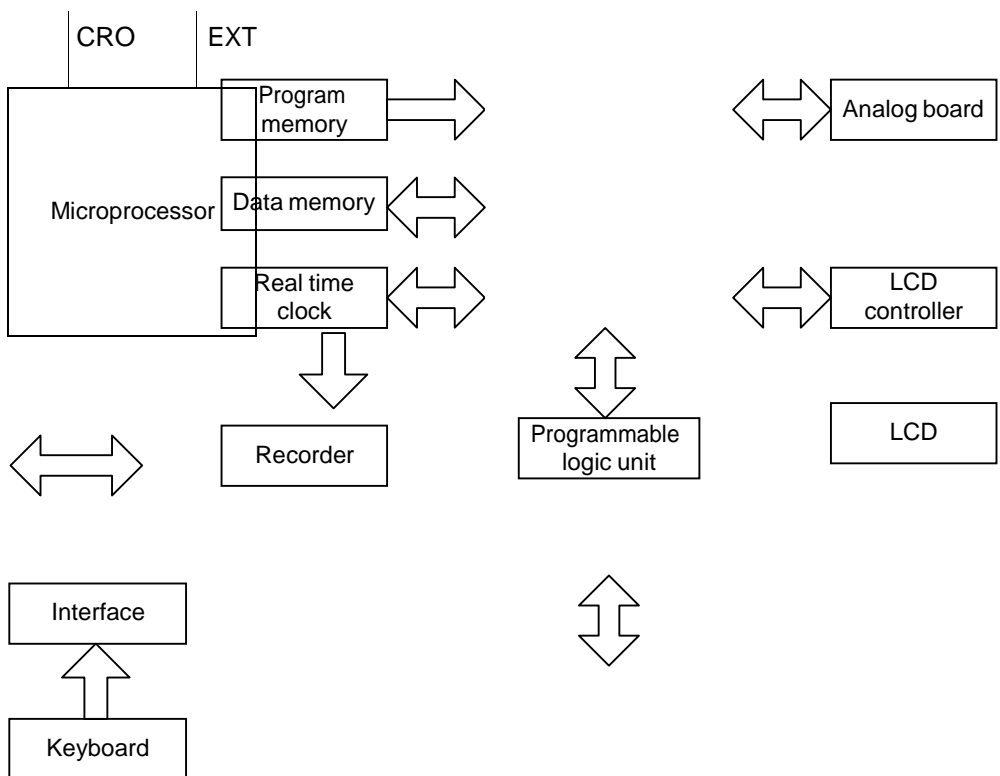

Appendix D List of Interpretation Codes and Corresponding Description

8 Arrhythmia	
8002	Marked rhythm irregularity
8110	Sinus rhythm
8102	Sinus arrhythmia
8108	Marked sinus arrhythmia
8120	Sinus tachycardia
8130	Sinus bradycardia
8200	Atrial rhythm
8210	Atrial fibrillation
82101	Atrial fibrillation with rapid ventricular response
82102	Atrial fibrillation with slow ventricular response
82103	Atrial fibrillation with aberrant conduction, or ventricular premature
82108	Atrial fibrillation with rapid ventricular response with aberrant conduction, or ventricular
82109	Atrial fibrillation with slow ventricular response with ventricular premature
8220	Atrial tachycardia
8250	Atrial flutter
82503	Atrial flutter with aberrant conduction or ventricular premature complexes
82505	Cannot rule out atrial flutter
8300	Junctional rhythm
8320	Junctional tachycardia
8400	Supraventricular rhythm
8420	Supraventricular tachycardia
8430	Supraventricular bradycardia
8470	with occasional supraventricular premature complexes
8474	with frequent supraventricular premature complexes
8475	with frequent supraventricular premature complexes in a pattern of bigeminy
8500	Ventricular rhythm
8520	Ventricular tachycardia
8570	with occasional ventricular premature complexes
8574	with frequent ventricular premature complexes
8575	with frequent ventricular premature complexes in a pattern of bigeminy
8901	Undetermined regular rhythm
8902	Undetermined rhythm
8970	with occasional ectopic premature complexes
8974	with frequent ectopic premature complexes
8975	with frequent ectopic premature complexes in a pattern of bigeminy

8706	Electronic atrial pacemaker
8707	Electronic ventricular pacemaker
8708	Dual chamber Electronic pacemaker
8709	Demand pacemaker
8710	Pacemaker failure
85201	Ventricular Fibrillation
6 AV Conductive Defect	
611	Possible third degree AV block
621	Second degree AV block, Wenckebach type
622	Second degree AV block, Mobitz type II
623	First degree AV block
631	Short PR interval
641	Type-A WPW syndrome
642	Type-B WPW syndrome
643	Atypical WPW syndrome
644	Intermittent WPW syndrome
7 Intraventricular Conductive	
711	Left bundle branch block
712	Incomplete left bundle branch block
721	Right bundle branch block, plus RVH
722	Right bundle branch block
723	Incomplete right bundle branch block
724	RSR' in lead V1/V2, consistent with right ventricular conduction delay
731	Left anterior fascicular block
732	Left posterior fascicular block
741	Nonspecific intraventricular conduction block
742	Nonspecific intraventricular conduction delay
1 Myocardial	
1113	Cannot rule out anterior myocardial infarction, probably old
1114	Cannot rule out anterior myocardial infarction, age undetermined
1121	Possible anterior myocardial infarction, possible acute
1122	Possible anterior myocardial infarction, probably recent
1123	Possible anterior myocardial infarction, probably old
1124	Possible anterior myocardial infarction, age undetermined
1131	Anterior myocardial infarction, possible acute
1132	Anterior myocardial infarction, probably recent
1133	Anterior myocardial infarction, probably old
1134	Anterior myocardial infarction, age undetermined
1213	Cannot rule out anteroseptal myocardial infarction, probably old
1214	Cannot rule out anteroseptal myocardial infarction, age undetermined
1221	Possible anteroseptal myocardial infarction, possible acute

Appendix D List of Interpretation Codes and Corresponding Description

1222	Possible anteroseptal myocardial infarction, probably recent
1223	Possible anteroseptal myocardial infarction, probably old

Appendix D List of Interpretation Codes and Corresponding Description

1224	Possible anteroseptal myocardial infarction, age undetermined
1231	Anteroseptal myocardial infarction, possible acute
1232	Anteroseptal myocardial infarction, probably recent
1233	Anteroseptal myocardial infarction, probably old
1234	Anteroseptal myocardial infarction, age undetermined
1313	Cannot rule out anterolateral myocardial infarction, probably old
1314	Cannot rule out anterolateral myocardial infarction, age undetermined
1321	Possible anterolateral myocardial infarction, possible acute
1322	Possible anterolateral myocardial infarction, probably recent
1323	Possible anterolateral myocardial infarction, probably old
1324	Possible anterolateral myocardial infarction, age undetermined
1331	Anterolateral myocardial infarction, possible acute
1332	Anterolateral myocardial infarction, probably recent
1333	Anterolateral myocardial infarction, probably old
1334	Anterolateral myocardial infarction, age undetermined
1413	Cannot rule out septal myocardial infarction, probably old
1414	Cannot rule out septal myocardial infarction, age undetermined
1421	Possible septal myocardial infarction, possible acute
1422	Possible septal myocardial infarction, probably recent
1423	Possible septal myocardial infarction, probably old
1424	Possible septal myocardial infarction, age undetermined
1431	Septal myocardial infarction, possible acute
1432	Septal myocardial infarction, probably recent
1433	Septal myocardial infarction, probably old
1434	Septal myocardial infarction, age undetermined
1513	Cannot rule out lateral myocardial infarction, probably old
1514	Cannot rule out lateral myocardial infarction, age undetermined
1521	Possible lateral myocardial infarction, possible acute
1522	Possible lateral myocardial infarction, probably recent
1523	Possible lateral myocardial infarction, probably old
1524	Possible lateral myocardial infarction, age undetermined
1531	Lateral myocardial infarction, possible acute
1532	Lateral myocardial infarction, probably recent
1533	Lateral myocardial infarction, probably old
1534	Lateral myocardial infarction, age undetermined
1613	Cannot rule out inferior myocardial infarction, probably old
1614	Cannot rule out inferior myocardial infarction, age undetermined
1621	Possible inferior myocardial infarction, possible acute
1622	Possible inferior myocardial infarction, probably recent
1623	Possible inferior myocardial infarction, probably old
1624	Possible inferior myocardial infarction, age undetermined

Appendix D List of Interpretation Codes and Corresponding Description

1631	Inferior myocardial infarction, possible acute
1632	Inferior myocardial infarction, probably recent

1633	Inferior myocardial infarction, probably old
1634	Inferior myocardial infarction, age undetermined
16132	Cannot rule out inferior myocardial infarction with posterior extension,
16142	Cannot rule out inferior myocardial infarction with posterior extension, age
16212	Possible inferior myocardial infarction with posterior extension, possible acute
16222	Possible inferior myocardial infarction with posterior extension, probably
16232	Possible inferior myocardial infarction with posterior extension, probably old
16242	Possible inferior myocardial infarction with posterior extension, age
16312	Inferior myocardial infarction with posterior extension, possible acute
16322	Inferior myocardial infarction with posterior extension, probably recent
16332	Inferior myocardial infarction with posterior extension, probably old
16342	Inferior myocardial infarction with posterior extension, age undetermined
171	Abnormal Q wave ? [Lat.]
172	Abnormal Q wave ? [Inf.]
173	Abnormal Q wave ? [Lat., Inf.]
174	Abnormal Q wave ? [Ant.]
175	Abnormal Q wave ? [Ant., Lat.]
176	Abnormal Q wave ? [Ant., Inf.]
177	Abnormal Q wave ?
3	Ventricular Hypertrophy and Atrial
311	Possible right ventricular hypertrophy
312	Right ventricular hypertrophy
313	Right ventricular hypertrophy, probably repolarization abnormality
321	Minimal voltage criteria for LVH
322	Possible left ventricular hypertrophy
323	left ventricular hypertrophy
324	Left ventricular high voltage (moderate)
325	Left ventricular hypertrophy, probably repolarization abnormality
331	Possible left atrial enlargement
332	Left atrial enlargement
341	Possible right atrial enlargement
342	Right atrial enlargement
2	Axis Deviation
21	Moderate left axis deviation
22	Abnormal left axis deviation
23	S1-S2-S3 pattern
24	Abnormal right axis deviation
25	Moderate Right axis deviation
26	Indeterminate axis
2	ST-T Abnormality
2101	ST depression, possible digitalis effect

Appendix D List of Interpretation Codes and Corresponding Description

2102	Minimal ST depression
2103	Moderate ST depression

2104	Marked ST depression, possible subendocardial injury
2105	Marked ST depression, possible subendocardial injury or Digitalis effect
2106	Marked ST depression, consistent with subendocardial injury
2107	Junctional ST depression, probably normal
2108	Abnormal junctional ST depression
2111	Possible anterior injury or acute infarct
2112	Anterior injury or acute infarct
2113	Possible anteroseptal injury or acute infarct
2114	Anteroseptal injury or acute infarct
2115	Possible anterolateral subepicardial injury
2116	Anteroseptal subepicardial injury
2117	Possible septal subepicardial injury
2118	Septal subepicardial injury
2119	Possible lateral subepicardial injury
21110	Lateral subepicardial injury
21111	Possible inferio injury or acute infarct
21112	Inferio injury or acute infarct
2121	T wave abnormality, possible anterior ischemia
2122	T wave abnormality, possible anterior ischemia or digitalis effect
2123	T wave abnormality, consistent with anterior ischemia
2124	T wave abnormality, possible anterolateral ischemia
2125	T wave abnormality, possible anterolateral ischemia or digitalis effect
2126	T wave abnormality, consistent with anterolateral ischemia
2127	T wave abnormality, possible lateral ischemia
2128	T wave abnormality, possible lateral ischemia or digitalis effect
2129	T wave abnormality, consistent with lateral ischemia
21210	T wave abnormality, possible inferio ischemia
21211	T wave abnormality, possible inferio ischemia or digitalis effect
21212	T wave abnormality, consistent with inferio ischemia
2131	ST elevation, probably early repolarization
2132	Early repolarization
2133	ST elevation, consistent with subepicardial injury, pericarditis, or Early
2141	Possible acute percarditis
2142	acute percarditis
2151	Nonspecific ST&T wave abnormality
2152	Nonspecific ST&T wave abnormality, probably digitalis effect
2153	Tall T waves, possible hyperkalemia
2154	Nonspecific T wave abnormality
2155	Nonspecific T wave abnormality, probably digitalis effect
2161	Nonspecific ST elevation

9 Others	
911	Low voltage
912	Low voltage in limb leads
913	Low voltage in chest leads
941	Long QT interval
942	Short QT interval
971	Dextrocardia ?
972	LIMB LEADS REVERSED
973	Abnormal QRS-T angle
974	Consistent with pulmonary disease
981	Artifacts present
982	Cannot be analyzed, re-record recommended
10 Overall Judgment	
1010	Normal ECG
1011	Borderline ECG
1012	Atypical ECG
1013	Abnormal rhythm ECG
1014	Abnormal ECG

 **CAUTION**

List of Interpretation codes may be subject to changes without notice.

Appendix E Measurement, Diagnosis, Analysis and Assessment of ECG Machine

Methods to determine the amplitude of P, QRS, ST and T wave

P wave amplitude

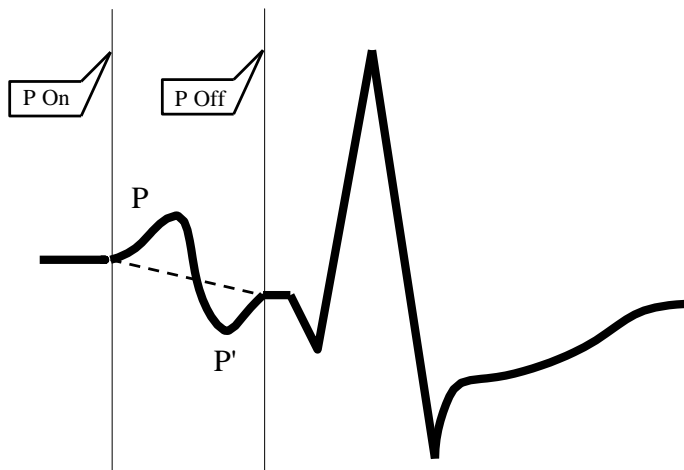

P On is the starting position of P wave, P Off is the ending position of P wave, and dashed line is the reference baseline

To measure P wave amplitude: the line from the starting point to the ending point of P wave is the reference baseline, as shown in above Figure. The positive amplitude is from the reference baseline to top edge of P wave; the negative amplitude is from the reference baseline to bottom edge of P wave.

QRS complex, ST segment and T wave amplitude

When measuring QRS complex, ST segment and T wave amplitude, the horizontal line of QRS complex beginning part is used as the reference baseline, as shown below:

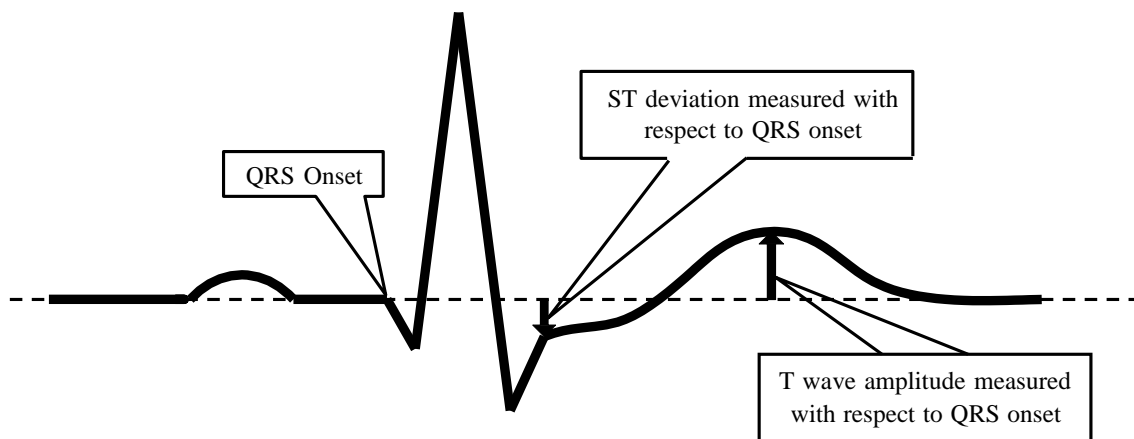

The measurement of QRS complex, ST segment and T wave amplitude uses the horizontal line of QRS complex beginning part as the reference baseline QRS Onset is the starting position of QRS wave

Processing method of isoelectric segment in QRS complex

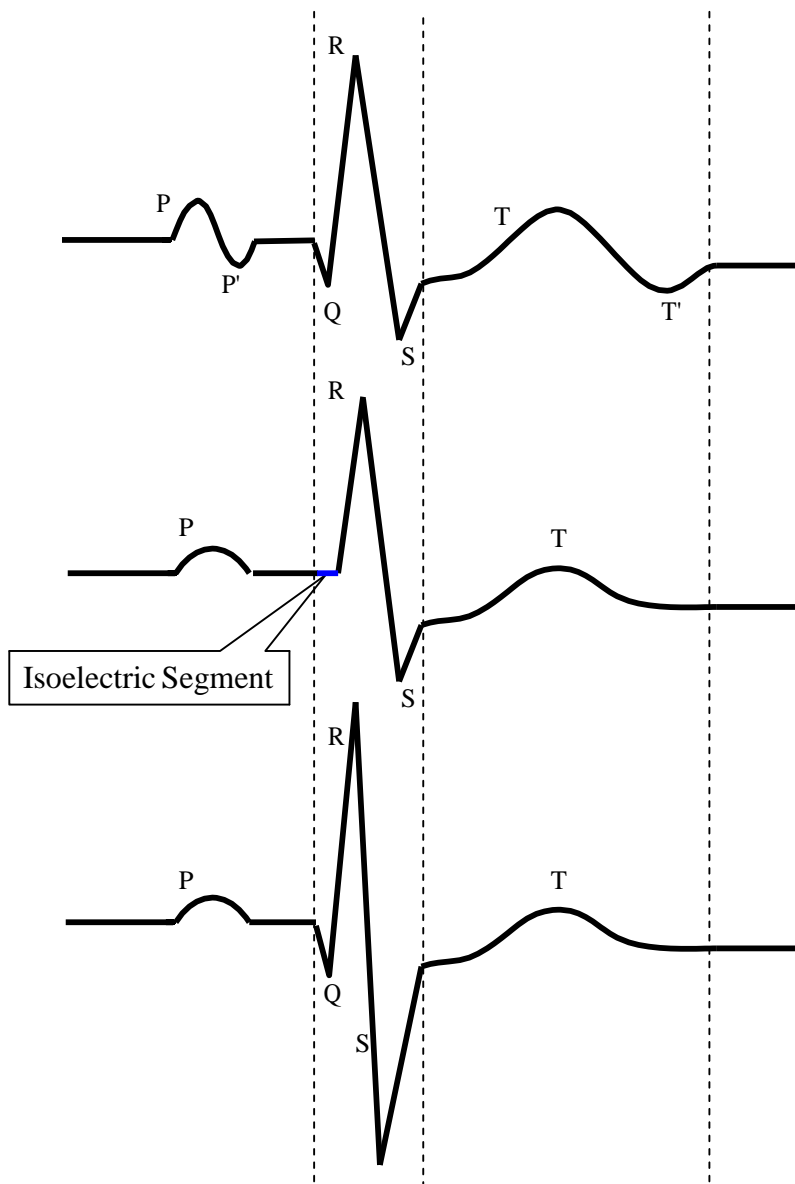

Isoelectric segment between dash lines are in QRS complex

As shown above, the isoelectric segment beginning from the starting position of QRS complex is processed as a part of QRS complex, but doesn't belong to the meaningful wave later (waveform area is larger than $160 \mu V \mu s$)

3 Low incidence heart disease not included in testing and diagnosis database

Test with CSE database, but this database doesn't have sufficient number of acute myocardial infarction and myocardial ischemia ECG.

4 ECG diagnosis categories and the number of ECG test of each category

The accuracy of disease diagnosis and non-ECG means used to verify the effectiveness of heart disease diagnosis, as well as the patients statistics data (e.g. age, gender, race) of each group.

Test with CSE database, the following Table lists disease diagnostic categories, the number of ECG testing of each category and the accuracy of disease diagnosis.

CSE database sample properties are as follows:

Total number of samples: 1220 (male: 831, female: 389) Race: White

Age: 52 □ □ 13

Type of disease	ECG test number	Sensitivity (%)	Specificity (%)	Positive predictive value (%)
Normal	382	92.7	73.9	61.8
Left ventricular hypertrophy	183	60.1	97.0	77.7
Right ventricular hypertrophy	55	32.7	99.9	92.3
Biventricular hypertrophy	53	26.4	99.9	93.3
Anterior wall myocardial infarction	170	80.6	97.7	85.1
Inferior wall myocardial infarction	273	67.0	97.8	89.7
Composite myocardial infarction	73	64.7	99.7	94.0
Hypertrophy and myocardial infarction	31	46.8	100.0	100.0

The smallest waveform identified by the device and the stability of measurement when noise exists

If the area of certain waveform is greater than or equal to $160 \mu V \mu s$, it is considered as meaningful wave, otherwise it is meaningless. Recognizing meaningful waveforms in area method can effectively reduce the noise. The stability of the measurement when noise exists is shown below

Overall measurement parameter	Type of added noise	Mean difference (ms)	Variance (ms)
P time limit	High frequency	-0.1	0.64
	Power frequency	0.25	1.5
	Low frequency	-2.3	3.8
PR interval	High frequency	1.6	2.4
	Power frequency	-0.1	1.5
	Low frequency	0.38	9.5
QRS time limit	High frequency	0.75	4.0
	Power frequency	-1.1	1.7
	Low frequency	0.3	4.4
QT interval	High frequency	-1.6	3.6
	Power frequency	-0.5	1.2
	Low frequency	4.9	5.6

Low incidence cardiac rhythm not included in the ECG rhythm test database

The low incidence cardiac rhythms not included in the test database:

Grade II conduction block;

Grade III conduction block.

7 ECG rhythm diagnosis categories and ECG test number of each category

Accuracy of rhythm diagnosis and the patient statistics data (e.g. age, gender, race) of each group

The following Table gives the rhythm categories, ECG test number of each category and accuracy of disease diagnosis.

The test database sample properties are as follows:

Total number of sample: 4500 (male: 2847, female: 1653) Race: Yellow

Age: 48 □ □ 12

Rhythm type	ECG test number	Sensitivity (%)	Specificity (%)	Positive predictive value (%)
Sinus rhythm	3656	98.0	91.1	97.9
Premature ventricular contractions	351	87.2	98.9	81.2
Supraventricular premature beats	247	68.8	99.6	89.9
Atrial fibrillation	192	89.6	98.7	91.0
Atrial flutter	49	65.3	99.9	88.9
Pacemaker rhythm	5	100.0	100.0	100.0

Sensitivity regularly test instructions

Inspect ECGs: EGC-1C Inspection methods:

Make ECG machine set in lead I, the sensitivity is set as 10 mm/mV., EGC-1C transmits the U_{in} as 1 mV, frequency 10 Hz sine wave signal to the ECG machine.

Test the waveform amplitude h_m on the Inspected ECG machine. Calculate the corresponding to deviations of the sensitivity according to the following formula, should meet the maximum allowable relative deviation

of ± 5

%.

$$\frac{|S_m - S_n|}{S_n} \leq 100\%$$

$$\frac{|S_m - S_n|}{S_n} \leq 100\%$$

The formula: S_n - nominal value of Sensitivity;

S_m -test value of sensitivity;

h_m -the waveform amplitude of sensitivity;

U_{in} -input signal amplitude if the inspected ECG machine

Make ECG machine set in lead I, the sensitivity is set as 20 mm/mV. EGC-1C transmits the U_{in} as 0.5 mV, frequency 10 Hz sine wave signal to the ECG machine. Using the same method to test the relative deviation of 20 mm/mV sensitivity.

Make ECG machine set in lead I, the sensitivity is set as 5 mm/mV. EGC-1C transmits the U_{in} as 2 mV, frequency 10 Hz sine wave signal to the ECG machine. Using the same method to test the relative deviation of 5 mm/mV sensitivity.

Make ECG machine set in lead I, the sensitivity is set as 2.5mm/mV. EGC-1C transmits the U_{in} as 4 mV, frequency 10 Hz sine wave signal to the ECG machine. Using the same method to test the relative deviation of 2.5 mm/mV sensitivity.

According to the 1 and 2 steps to change the leads of the ECG machine, and make the EGC-1C's output signals connected to corresponding lead of the ECG machine, to complete all channel's inspect, and then select the largest relative deviation from the test results for each test point, as the result of the inspection.

Distortion Test

The function of ECG machine will not be affected adversely by the running of the pacemaker, which can be verified in the following way:

Superimpose the pulse wave of 200 mV peak, rise time less than 100 μ s, 1ms pulse width, and 100 beats / min repetition rate with the sine wave signal of 1mV peak-valley value and 40 Hz frequency, and input to the ECG machine (set to standard sensitivity). The time required to restore the sine wave signals recorded by the ECG machine to 70 % of the initial value (when peak-valley value is 1mV and gain is 10 mm/mV, the initial value should be 10 mm) shouldn't exceed 50 ms; in the above test, the maximum baseline drift accumulated in 10 s doesn't exceed 10 mm; both with and without pulse, the amplitude difference recorded by sine wave signals (after waveform is stable) isn't greater than ± 1 mm.

The filter of ECG machine must be opened for distortion tests.

The ECG machine can pass one of the following two tests:

String the pacemaker pulse wave of 200 mV peak, rise time less than 100 μ s, 1ms pulse width, and 120

pulses / min repetition rate together with the symmetrical triangular wave of 2 mV amplitude and 100 ms duration. The starting time of pulse wave should be 40 ms earlier (or later) than the starting time of triangular wave, input such a signal to the ECG machine, record in the standard sensitivity, the triangular wave is clearly visible on the ECG machine records, the difference between recorded amplitude and the original amplitude (the original amplitude of the waveform with 2 mV amplitude should be 20 mm under 10 mm/mV gain) does not exceed 20 %, and the location of the pacemaker pulse can be clearly identified in the ECG machine records.

String the pacemaker pulse wave of 200 mV peak, rise time less than 100 μ s, 1ms pulse width, and 120 pulses / min repetition rate together with the ECG calibration signal CAL20000, and input to the ECG machine. The QRS curve of calibration signal can be clearly identified on ECG machine records, the difference between the recorded amplitude and the original amplitude of QRS curve does not exceed 20%, and the location of the pacemaker pulse can be clearly identified in the ECG machine records

Appendix F EMC-Guidance and manufacture’s declaration

⚠ CAUTION

The use of accessories, sensor and cable which exceed regulations can increase the electromagnetic emissions or decrease the electromagnetic immunity.

Please don’t use the equipment with tightness and pile. The equipment should be detected according to the requirements to make sure it working normally. Please make the equipment safety according to the EMC, and install, fix it under the situation required by EMC.

Even though the other equipments which measure up the CISPR also may cause disturbance.

When the amplitude of import signal narrow than regulated minimum amplitude may lead to inaccurate measure.

Portable and mobile communications equipment will affect the performance of the equipment.

1 Guidance and manufacturer’s declaration – electromagnetic emission

Guidance and manufacturer’s declaration – electromagnetic emission		
The Digital Electrocardiograph is intended for use in the electromagnetic environment specified below. The customer or the user of the ECG machine should assure that it is used in such an environment.		
Emissions test	Compliance	Electromagnetic environment - guidance
RF emissions CISPR 11	Group 1	The ECG machine uses RF energy only for its internal function. Therefore, its RF emissions are very low and are not likely to cause any interference in nearby electronic equipment.
RF emissions CISPR 11	Class A	The ECG machine is suitable for use in all establishments, including domestic establishments and those directlyconnected to the public low-voltage power supplynetwork that supplies buildings used for domestic purposes.
Harmonic emissions EN 61000-3-2	Class A	
Voltage fluctuations /flicker emissions	Complies	

EN 61000-3-3

Guidance and manufacture's declaration-electromagnetic immunity for all EQUIPMENT and SYSTEMS.

Guidance and manufacture's declaration-electromagnetic immunity			
The ECG machine is intended for use in the electromagnetic environment specified below. The customer of the			
user of the ECG machine should assure that it is used in such an environment			
Immunity test	IEC60601 test level	Compliance level	Electromagnetic environment guidance
Electrostatic discharge (ESD) IEC61000-4-2	±6KV contact ±8KV air	±6KV contact ±8KV air	Floors should be wood, concrete or ceramic tile. If floor are covered with synthetic material, the relative humidity should be at least 30%
Electrical fast transient/burst IEC61000-4-4	±2KV for power supply lines ±1KV for input/output lines	±1KV for power supply lines ±1KV for input/output lines	Mains power quality should be that of a typical commercial or hospital environment.
Surge IEC61000-4-5	±1KV differential mode ±2KV common mode	±1KV differential mode ±2KV common mode	Mains power quality should be that of a typical commercial or hospital environment.
Voltage dips, short interruptions and voltage variation power supply input lines IEC61000-4-11	<5% UT (>95% dip in UT) for 0.5 cycle 40% UT (60% dip in UT) for 5 cycle 70% UT	<5% UT for 0.5 cycle 40% UT for 5 cycle 70% UT	Main power quality should be that of a typical commercial or hospital environment. If the user of the ECG machine requires Continued operation during power mains interruptions, it is recommended that the ECG

	(30% dip in UT) for 25 cycles <5% UT (>95% dip in UT) for 5 sec	for 25 cycles <5% UT for 5 sec	machine be powered from an uninterruptible power supply or a battery.
Power frequency (50Hz) magnetic field IEC61000-4-8	3A/m	3A/m	Mains power quality should be that of a typical commercial or hospital environment.
NOTE: UT is the A.C mains voltage prior to application of the test level.			

Guidance and manufacture's declaration-electromagnetic immunity for EQUIPMENT and SYSTEMS those are not LIFE-SUPPORTING

Guidance and manufacture's declaration-electromagnetic immunity			
The ECG machine is intended for use in the electromagnetic environment specified below. The customer of the user of the ECG machine should assure that it is used in such an environment.			
Immunity test	IEC60601 test level	Compliance level	Electromagnetic environment-guidance
Conducted RF IEC61000-4-6	3 Vrms 150kHz -80 MHz	3 Vrms	Portable and mobile RF communications equipment should be used no closer to any part of the ECG machine, including cables, than the recommended separation distance calculated from the equation applicable to the frequency of the transmitter. Recommended separation distance $d \geq \sqrt{\frac{3.5 \times P}{V_1}}$ $d \geq \sqrt{\frac{3.5 \times P}{E_1}}$ P 80MHz-800 MHz

<p>Radiated RF IEC61000-4-3</p>	<p>3 V/m 80 MHz -2.5 GHz</p>	<p>3 V/m</p>	<p> $E_1 \leq \frac{\sqrt{P}}{d} \times 7$ P 800MHz-2.5 GHz Where P is the maximum output power rating of the transmitter in watts (W) according to the transmitter manufacturer and d is the recommended separation distance in metres (m). Field strengths from fixed RF transmitters, as determined by an electromagnetic site survey, range ^a should be less than the compliance level in each frequency range.^b Interference may occur in the vicinity of Equipment marked with the following symbol: </p> 
<p>NOTE1: At 80MHz and 800MHz, the higher frequency range applies. NOTE2: These guidelines may not apply in all situations. Electromagnetic propagation is affected by absorption and reflection from structures, objects and people.</p>			
<p>a. Field strengths from fixed transmitters, such as base stations for radio (cellular/cordless) telephones and land mobile radios, amateur radio, AM and FM radio broadcast and TV broadcast cannot be predicted theoretically with accuracy. To assess the electromagnetic environment due to fixed RF transmitters, an electromagnetic site survey should be considered. If the measured field strength in the location in which the ECG machine should be observed to verify normal operation. If abnormal performance is observed, additional measures may be necessary, such as reorienting or relocating the ECG machine. b. Over the frequency range 150kHz to 80 MHz, field strengths should be less than 3V/m.</p>			

Recommended separation distance between portable and mobile RF communications equipment and the EQUIPMENT or SYSTEM for EQUIPMENT or SYSTEM that are not LIFE-SUPPORTING

Recommended separation distance between portable and mobile RF communications equipment and the ECG machine			
The ECG machine is intended for use in an electromagnetic environment in which radiated RF disturbances are controlled. The customer or the user of the ECG machine can help prevent electromagnetic Interference by maintaining a minimum distance between portable and mobile RF communications equipment (transmitters) and the ECG machine as recommended below according to the maximum output power of the communications equipment.			
Rated maximum output power of transmitter (W)	Separation distance according to frequency of transmitter (m)		
	150 kHz-80 MHz	80 MHz-800 MHz	800 MHz-2.5 GHz
	$d = 3.5 \sqrt{P}$	$d = 3.5 \sqrt{P}$	$d = 7 \sqrt{P}$
0.01	0.12	0.12	0.23
0.1	0.38	0.38	0.73
1	1.2	1.2	2.3
10	3.8	3.8	7.3
100	12	12	23
For transmitters rated at a maximum output power not listed above, the recommended separation distance in meters (m) can be estimated using the equation applicable to the frequency of the transmitter, where P is the maximum output power rating of the transmitter in watts (W) according to the transmitter manufacturer. NOTE1: At 80MHz and 800MHz, the higher frequency range applies. NOTE2: These guidelines may not apply in all situations. Electromagnetic propagation is affected by absorption and reflection from structures, objects and people.			